

PROJECT: I-5977

CONTRACT: DD00208

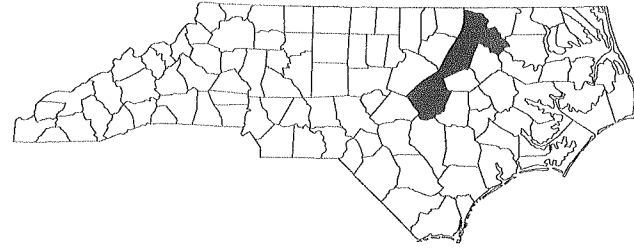

STATE OF NORTH CAROLINA
DIVISION OF HIGHWAYS

HALIFAX, NASH & JOHNSTON COUNTIES

STATE	STATE PROJECT REFERENCE NO.	SHEET NO.	TOTAL SHEETS
N.C.	I-5977	1	37
STATE PROJ. NO.	F.A. PROJ. NO.	DESCRIPTION	
44977.3.1		CONST.	

LOCATION:

HALIFAX COUNTY **BRIDGE #12 ON I-95 NBL OVER FISHING CREEK.**
BRIDGE #13 ON I-95 SBL OVER FISHING CREEK.

NASH COUNTY **BRIDGE #128 NBL ON I-95 OVER SAPONY CREEK.**
BRIDGE #133 SBL ON I-95 OVER SAPONY CREEK.

JOHNSTON COUNTY **BRIDGE #482 ON I-40 WBL OVER NC 96.**
BRIDGE #483 ON I-40 EBL OVER NC 96.

TYPE OF WORK: BRIDGE PRESERVATION WITH EPOXY OVERLAY SYSTEM, JOINT DEMOLITION, SUPERSTRUCTURE REPAIRS, AND SUBSTRUCTURE REPAIRS.

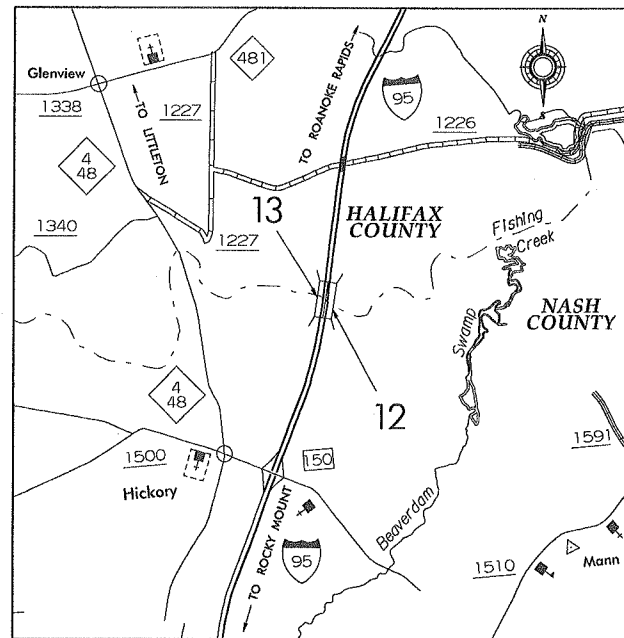

HALIFAX COUNTY

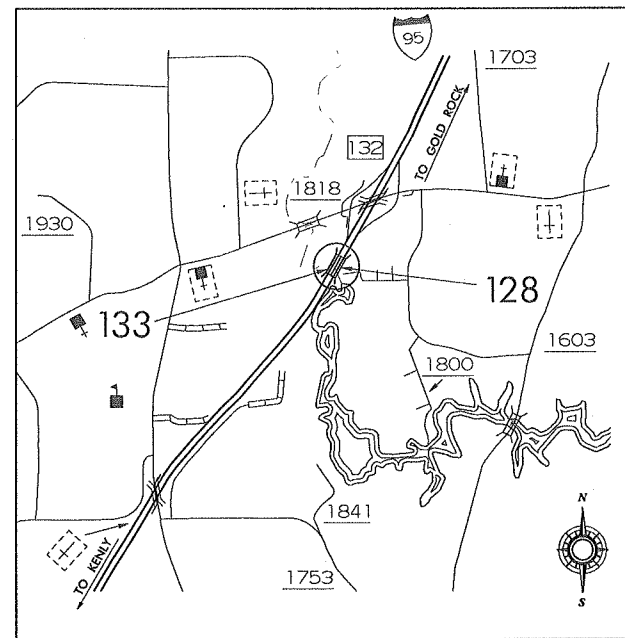

NASH COUNTY

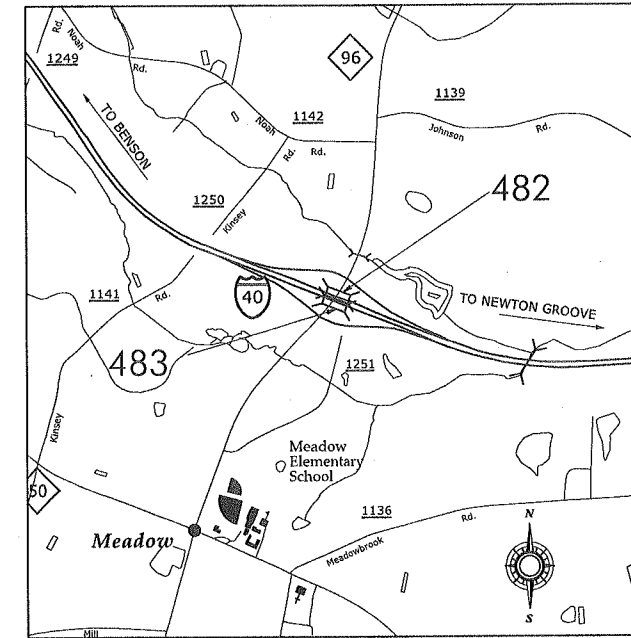

JOHNSTON COUNTY

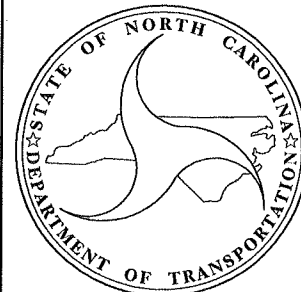

DESIGN DATA

HALIFAX COUNTY		
#12 ADT 2012	=	17,000
#13 ADT 2012	=	17,000
NASH COUNTY		
#128 ADT 2011	=	17,500
#133 ADT 2011	=	17,500
JOHNSTON COUNTY		
#482 ADT 2012	=	10,000
#483 ADT 2011	=	10,000

PROJECT LENGTH

HALIFAX COUNTY		
#12	=	0.046 MILE
#13	=	0.046 MILE
NASH COUNTY		
#128	=	0.029 MILE
#133	=	0.029 MILE
JOHNSTON COUNTY		
#482	=	0.028 MILE
#483	=	0.028 MILE

Prepared in the Office of:
DEPARTMENT OF TRANSPORTATION
DIVISION OF HIGHWAYS
STRUCTURES MANAGEMENT UNIT - PRESERVATION & REPAIR GROUP
 1000 BIRCH RIDGE DR. RALEIGH, N.C. 27610

ERIC B. NELSON, P. E.
PROJECT ENGINEER

2012 STANDARD SPECIFICATIONS

LETTING DATE:
MARCH 28, 2017

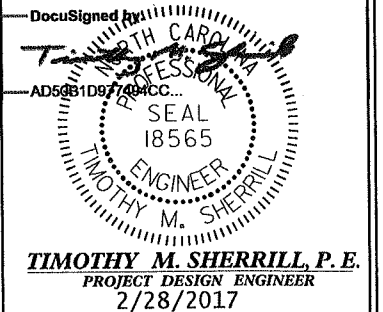

PROJECT: I-5977

CONTRACT: DD00208

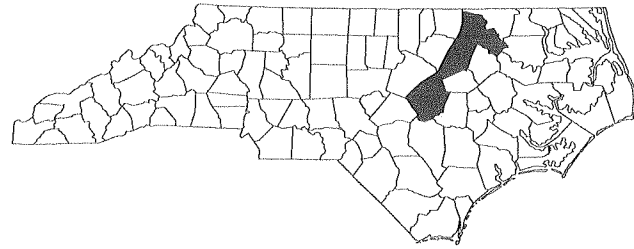

STATE OF NORTH CAROLINA
DIVISION OF HIGHWAYS

HALIFAX, NASH & JOHNSTON COUNTIES

STATE	STATE PROJECT REFERENCE NO.	SHEET NO.	TOTAL SHEETS
N.C.	I-5977	1A	37
STATE PROJ. NO.	F.A. PROJ. NO.	DESCRIPTION	
44977.3.1		CONST.	

LOCATION: HALIFAX COUNTY BRIDGE #12 ON I-95 NBL OVER FISHING CREEK.
BRIDGE #13 ON I-95 SBL OVER FISHING CREEK.

NASH COUNTY BRIDGE #128 NBL ON I-95 OVER SAPONY CREEK.
BRIDGE #133 SBL ON I-95 OVER SAPONY CREEK.

JOHNSTON COUNTY BRIDGE #482 ON I-40 WBL OVER NC 96.
BRIDGE #483 ON I-40 EBL OVER NC 96.

TYPE OF WORK: BRIDGE PRESERVATION WITH EPOXY OVERLAY SYSTEM, JOINT DEMOLITION, SUPERSTRUCTURE REPAIRS, AND SUBSTRUCTURE REPAIRS.

INDEX OF SHEETS

<u>SHEET NO.</u>	<u>DESCRIPTION</u>
1	TITLE SHEET
1A	INDEX OF SHEETS
S-1	TOTAL BILL OF MATERIALS & LOCATION SKETCHES
S-2 THRU S-13	STRUCTURAL PLANS - BRIDGES #12 & #13
S-14	SHOTCRETE REPAIR TABLES - BRIDGE #12
S-15	SHOTCRETE REPAIR TABLES - BRIDGE #13
S-16	JOINT DETAILS - BRIDGES #12 & #13
S-17 THRU S-21	STRUCTURAL PLANS - BRIDGES #128 & #133
S-22	JOINT DETAILS - BRIDGES #128 & #133
S-23 THRU S-32	STRUCTURAL PLANS - BRIDGES #482 & #483
S-33	JOINT DETAILS - BRIDGES #482 & #483
S-34	SHOTCRETE REPAIR TABLES - BRIDGE #482
S-35	SHOTCRETE REPAIR TABLES - BRIDGE #483
S-36	GIRDER REPAIR DETAILS - BRIDGES #12, #13, #482 & #483
S-37	CAP, COLUMN, & RAIL REPAIR DETAILS - BRIDGES #12, #13, #482 & #483
SN	STANDARD NOTES

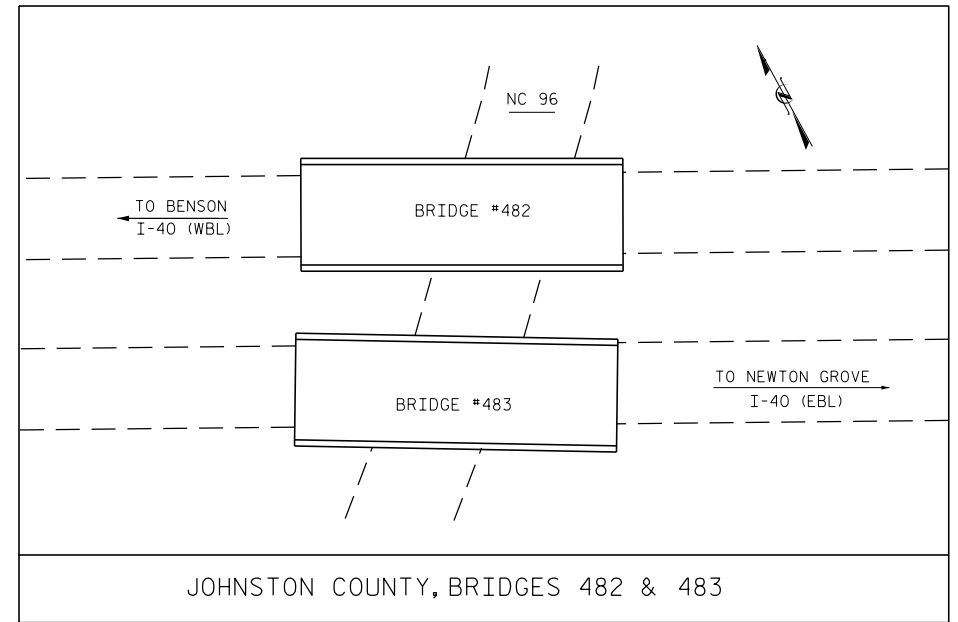
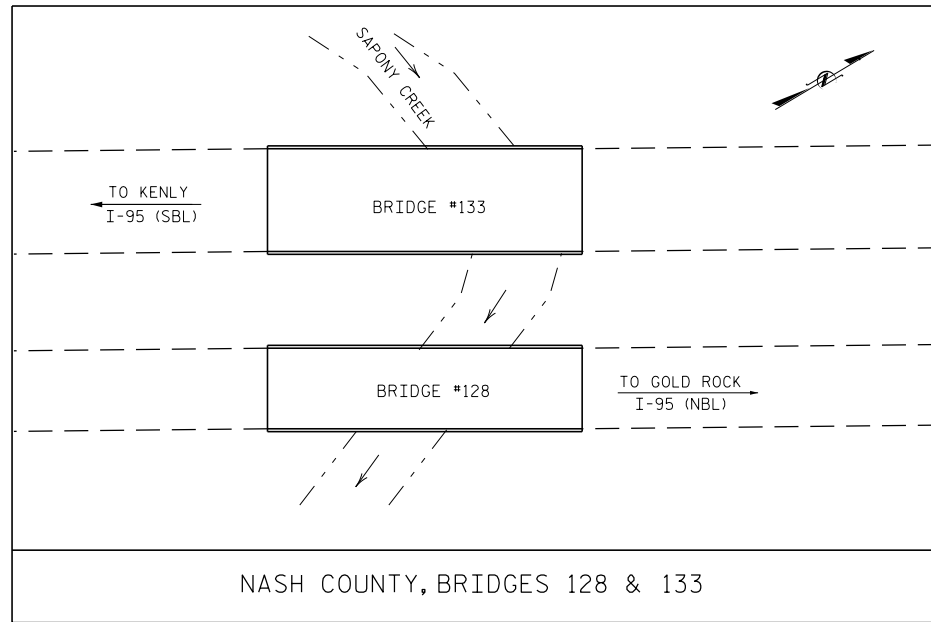
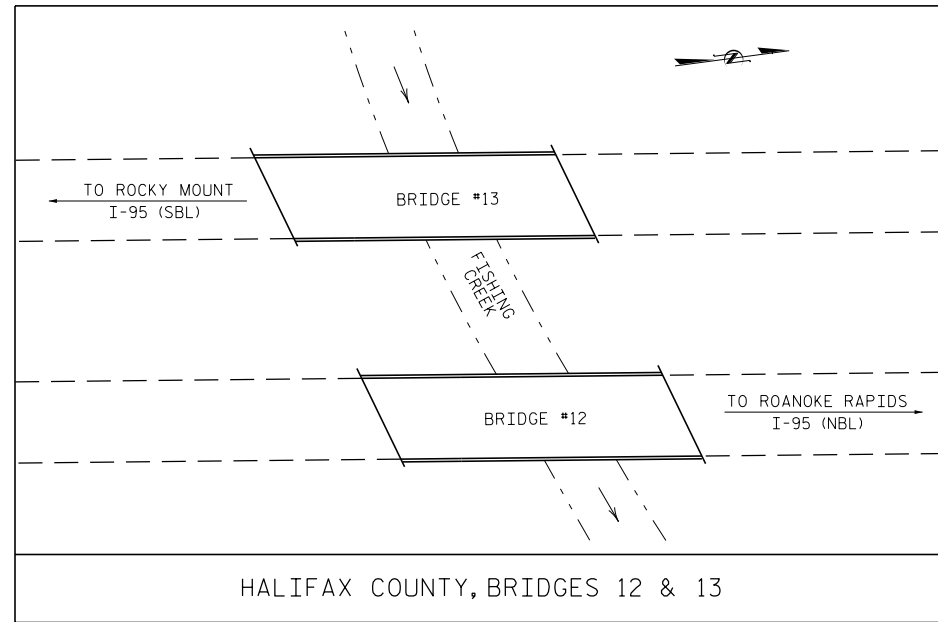

LOCATION SKETCHES

GENERAL NOTES:

INFORMATION INDICATED ON THE LOCATION SKETCH SHALL BE CONSIDERED GENERAL INFORMATION, ONLY. CONTRACTOR SHALL CONFIRM, THROUGH OTHER SOURCES, SPECIFIC INFORMATION REGARDING THE BRIDGES, ROADWAYS, UTILITIES, THE SURROUNDING AREA, AND ANY OTHER ASPECTS THAT MAY BE NECESSARY TO PERFORM AND COMPLETE THE PROJECT.

EXISTING DIMENSIONS AND BRIDGE CONDITION ARE FROM BEST INFORMATION AVAILABLE. THE CONTRACTOR SHALL FIELD VERIFY THE INFORMATION SHOWN ON THE PLANS AND NOTIFY THE ENGINEER IF ACTUAL DIMENSIONS AND CONDITIONS DIFFER.

IT IS THE CONTRACTOR'S RESPONSIBILITY TO FOLLOW ALL STATE AND FEDERAL SAFETY REQUIREMENTS.

EXISTING JOINTS AND DECK DRAINS SHALL BE SEALED PRIOR TO BEGINNING SURFACE PREPARATION OF BRIDGE DECK.

LONGITUDINAL CONSTRUCTION JOINTS OF OVERLAYS SHALL BE LOCATED ALONG THE CENTERLINE OR EDGE OF TRAVEL LANES.

FOR BRIDGE JOINT DEMOLITION, SEE SPECIAL PROVISIONS.

FOR ELASTOMERIC CONCRETE, SEE SPECIAL PROVISIONS.

FOR SUBMITTAL OF WORKING DRAWINGS, SEE SPECIAL PROVISIONS.

FOR FALSEWORK AND FORMWORK, SEE SPECIAL PROVISIONS.

FOR GROUT FOR STRUCTURES, SEE SPECIAL PROVISIONS.

FOR CONTROL OF TRAFFIC AND LIMITS ON PHASING OF CONSTRUCTION, SEE TRANSPORTATION MANAGEMENT PLAN.

FOR EPOXY OVERLAY SYSTEM, SEE SPECIAL PROVISION.

FOR CONCRETE DECK REPAIR FOR EPOXY OVERLAY, SEE SPECIAL PROVISION.

FOR CONCRETE REPAIRS, SEE SPECIAL PROVISIONS.

FOR SILICONE JOINT SEALANT, SEE SPECIAL PROVISIONS.

FOR EPOXY COATING AND DEBRIS REMOVAL, SEE SPECIAL PROVISIONS.

FOR SHOTCRETE REPAIRS, SEE SPECIAL PROVISIONS.

FOR EPOXY RESIN INJECTION, SEE SPECIAL PROVISIONS.

FOR REPLACEMENT OF FOAM JOINT SEALS, SEE SPECIAL PROVISIONS.

FOR PAINT CONTAINMENT, SEE SPECIAL PROVISIONS.

FOR CLEANING AND PAINTING EXISTING BEARINGS WITH HRCSA, SEE SPECIAL PROVISIONS.

FOR POLLUTION CONTROL, SEE SPECIAL PROVISIONS.

FOR CRANE SAFETY, SEE SPECIAL PROVISIONS.

TOTAL BILL OF MATERIAL

COUNTY	BRIDGE NO.	EPOXY COATING	SHOTCRETE REPAIR	EPOXY RESIN INJECTION	BRIDGE JOINT DEMOLITION	** CONCRETE DECK REPAIR FOR EPOXY OVERLAY	EPOXY OVERLAY SYSTEM	ELASTOMERIC CONCRETE	* CONCRETE REPAIRS	*** REPLACEMENT OF FOAM JOINT SEALS	SILICONE JOINT SEALANT	CLEANING AND PAINTING BEARINGS WITH HRCSA BRIDGE NO...	PAINT CONTAINMENT FOR BRIDGE NO...	POLLUTION CONTROL
		SQ. FT.	CU. FT.	LN. FT.	SQ. FT.	SQ. FT.	SQ. FT.	CU. FT.	CU. FT.	LN. FT.	LN. FT.	EACH	LUMP SUM	LUMP SUM
HALIFAX	12	944.0	30.7	40.5	-	-	-	-	1.0	88.0	-	60.0	LUMP SUM	LUMP SUM
	13	1000.0	45.2	99.5	-	-	-	-	1.0	88.0	-	60.0	LUMP SUM	LUMP SUM
NASH	128	-	-	-	64.0	30.0	7,143	16.0	-	-	48.0	-	-	-
	133	-	-	-	88.5	40.0	9,376	19.8	-	-	75.0	-	-	-
JOHNSTON	482	544.0	7.6	228.5	166.5	30.0	6,614	41.6	1.0	-	167.0	-	-	-
	483	544.0	3.7	209.5	166.5	30.0	6,614	41.6	1.0	-	167.0	-	-	-
TOTAL		3032.0	87.2	578.0	485.5	130.0	29,747	119.0	4.0	176.0	457.0	120.0	LUMP SUM	LUMP SUM

* TOKEN PAY ITEMS ARE INDICATED FOR PRICING PURPOSES, IN CASE UNANTICIPATED CONCRETE REPAIRS ARE ENCOUNTERED.

** CONCRETE DECK REPAIR FOR EPOXY OVERLAY IS NOT ANTICIPATED, TOKEN PAY ITEMS ARE INDICATED FOR PRICING PURPOSE IN CASE UNANTICIPATED REPAIR ARE ENCOUNTERED.

*** LENGTH OF JOINT SEALS TO BE REPLACED IS APPROXIMATE. CONTRACTOR AND ENGINEER SHALL INSPECT EXISTING SEALS TO DETERMINE ACTUAL QUANTITY OF JOINT SEALS TO REPLACE.

PROJECT NO. I-5977
HALIFAX, NASH
& JOHNSTON COUNTIES
 BRIDGE NO. 12, 13, 128, 133,
482, 483,

DocuSigned by:

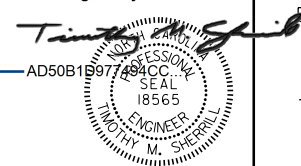

2/28/2017

STATE OF NORTH CAROLINA
 DEPARTMENT OF TRANSPORTATION
 RALEIGH
GENERAL NOTES
TOTAL BILL OF MATERIAL
 &
LOCATION SKETCHES

DRAWN BY : S. T. SANDOR DATE : 02/2017
 CHECKED BY : W. C. SMITH DATE : 02/2017

DOCUMENT NOT CONSIDERED FINAL UNLESS ALL SIGNATURES COMPLETED

REVISIONS						SHEET NO.
NO.	BY:	DATE:	NO.	BY:	DATE:	S-1
1			3			TOTAL SHEETS
2			4			37

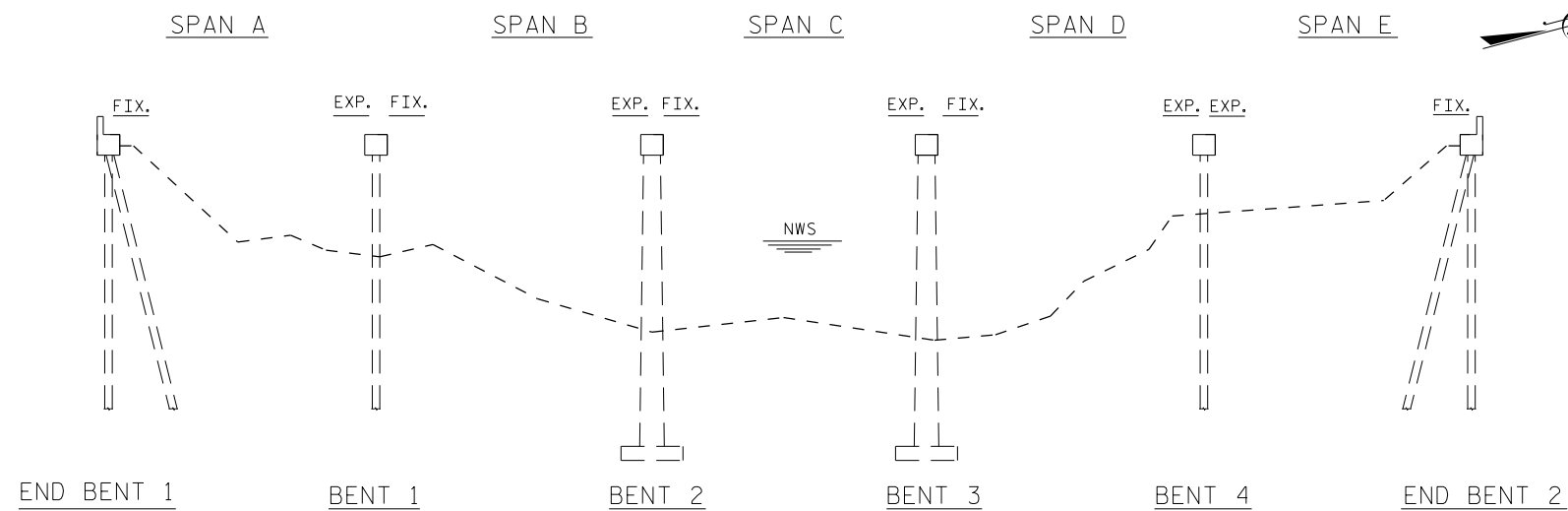

ELEVATION
(SECTION ALONG ϕ ROADWAY)

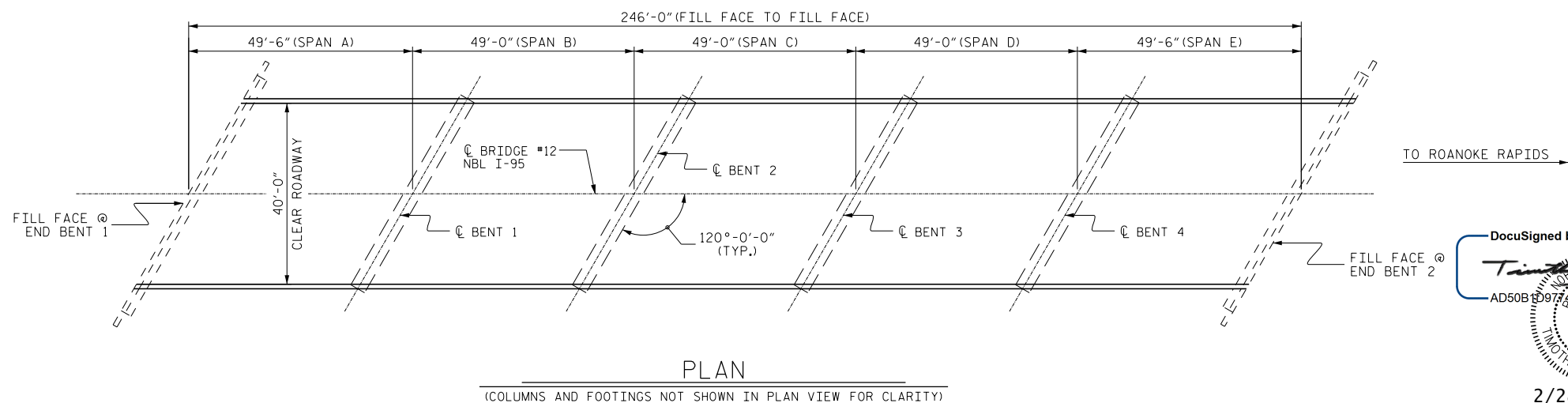
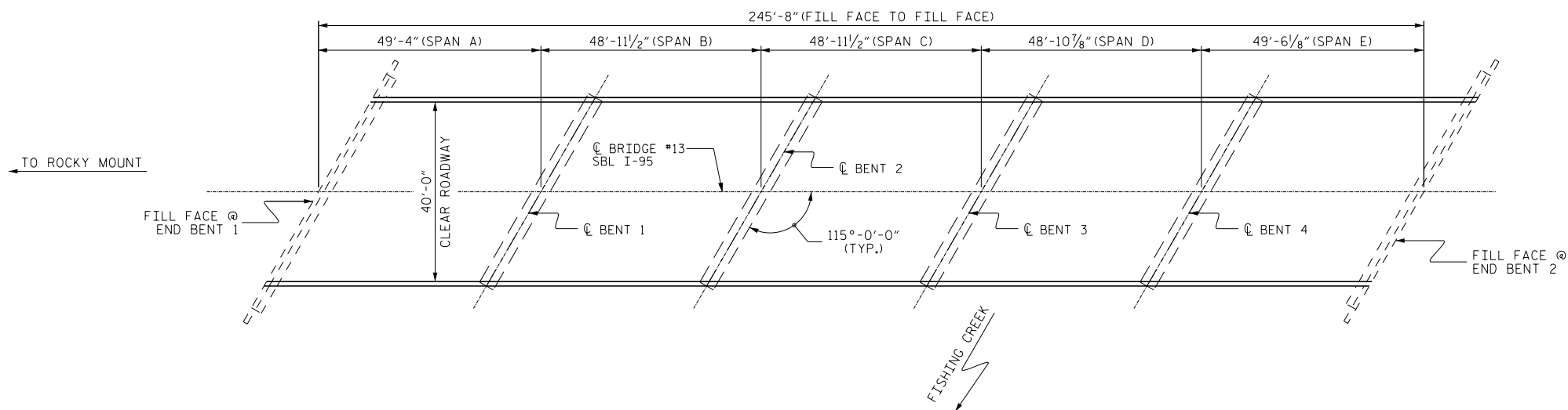

PLAN
(COLUMNS AND FOOTINGS NOT SHOWN IN PLAN VIEW FOR CLARITY)

SCOPE OF WORK

- SHOTCRETE REPAIRS AND EPOXY RESIN INJECTION OF GIRDERS, SUBSTRUCTURE, UNDERDECK, AND RAIL.
- CLEANING AND EPOXY COATING SUBSTRUCTURE CAPS.
- GIRDER REPAIRS.
- REPLACEMENT OF FOAM JOINT SEAL.

I hereby certify that this structure was rehabilitated according to these plans or as noted therein.

Resident Engineer Date

PROJECT NO. I-5977
 HALIFAX COUNTY
 BRIDGE NO. 12 & 13

DocuSigned by:
 Timothy M. Sherrill
 AD50B5D97740CC...
 PROFESSIONAL SEAL
 18565
 ENGINEER
 TIMOTHY M. SHERRILL
 2/28/2017

STATE OF NORTH CAROLINA
 DEPARTMENT OF TRANSPORTATION
 RALEIGH
 GENERAL DRAWING
 BRIDGE OVER FISHING
 CREEK ON I-95
 BETWEEN
 NC33 AND NC481

DRAWN BY : J. W. ARMFIELD / S. T. SANDOR DATE : 02/2017
 CHECKED BY : W. C. SMITH DATE : 02/2017

DOCUMENT NOT CONSIDERED FINAL UNLESS ALL SIGNATURES COMPLETED

REVISIONS						SHEET NO.
NO.	BY:	DATE:	NO.	BY:	DATE:	TOTAL SHEETS
1			3			S-2
2			4			37

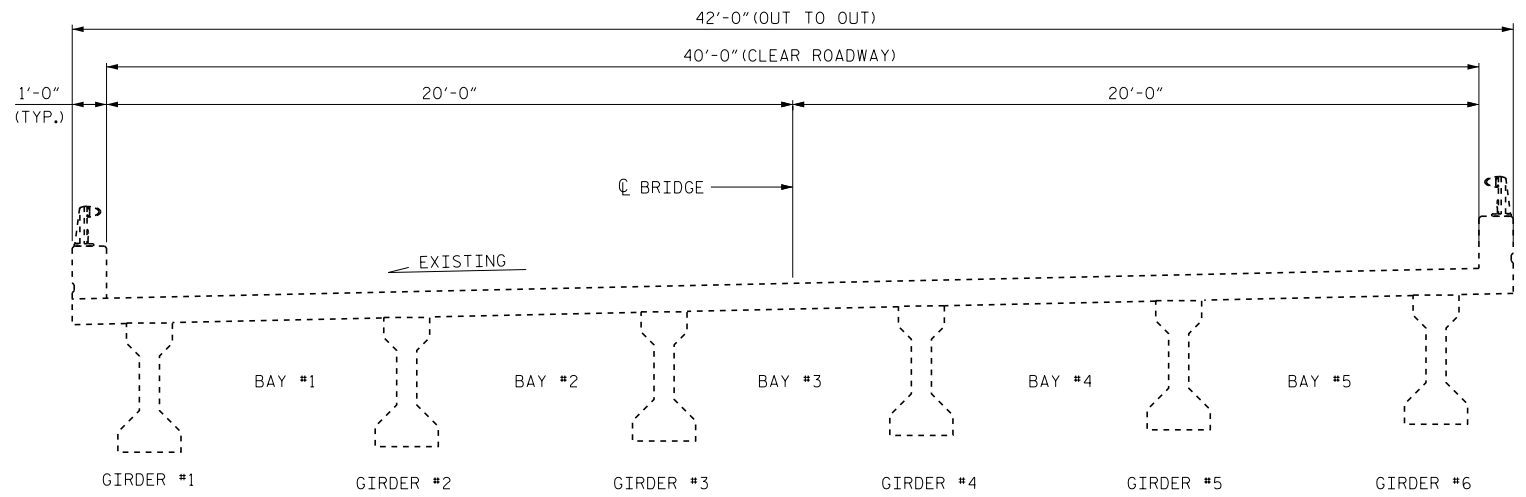

TYPICAL SECTION
(EXISTING BRIDGE #12)

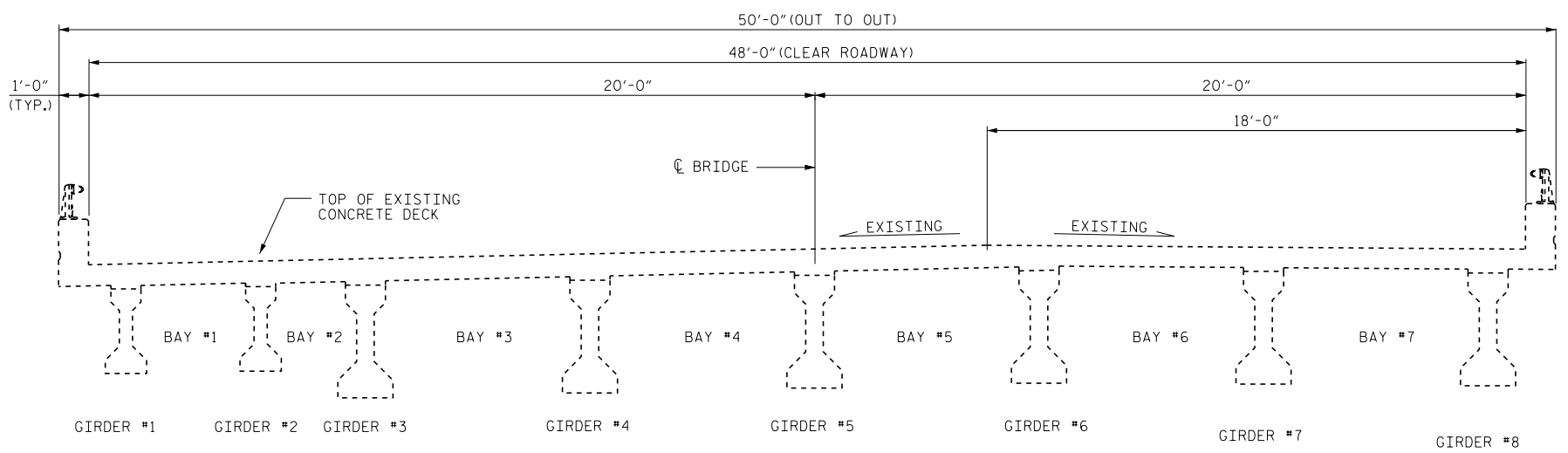

TYPICAL SECTION
(EXISTING BRIDGE #13)

PROJECT NO. I-5977
HALIFAX COUNTY
 BRIDGE NO. 12 & 13

DocuSigned by:
Timothy M. Shearill
 AD50B1D97784CC...
 PROFESSIONAL SEAL
 18565
 ENGINEER
 TIMOTHY M. SHEARILL
 2/28/2017

STATE OF NORTH CAROLINA
 DEPARTMENT OF TRANSPORTATION
 RALEIGH
 SUPERSTRUCTURE
 TYPICAL SECTION

DRAWN BY : S. T. SANDOR DATE : Q2/2017
 CHECKED BY : W. C. SMITH DATE : Q2/2017

REVISIONS						SHEET NO.
NO.	BY:	DATE:	NO.	BY:	DATE:	S-3
1			3			TOTAL SHEETS
2			4			37

REPAIR QUANTITY TABLE

END BENT 1	QUANTITIES			
	ESTIMATE		ACTUAL	
SHOTCRETE REPAIRS	AREA SF	VOLUME CF	AREA SF	VOLUME CF
CAP (VERTICAL FACE)	0.0	0.0		
CAP (HORIZONTAL, CORNER)	0.0	0.0		
EPOXY RESIN INJECTION		LN. FT.	LN. FT.	
CAP		0.0		
EPOXY COATING		AREA SF		
TOP OF CAP		130.0		

END BENT 2	QUANTITIES			
	ESTIMATE		ACTUAL	
SHOTCRETE REPAIRS	AREA SF	VOLUME CF	AREA SF	VOLUME CF
CAP (VERTICAL FACE)	0.0	0.0		
CAP (HORIZONTAL, CORNER)	0.0	0.0		
EPOXY RESIN INJECTION		LN. FT.	LN. FT.	
CAP		33.0		
EPOXY COATING		AREA SF		
TOP OF CAP		130.0		

NOTES:

REPAIR LOCATIONS AND ESTIMATE OF QUANTITIES ARE GIVEN WITH THE BEST INFORMATION AVAILABLE. IF ADDITIONAL REPAIRS NOT SHOWN ON THE DRAWINGS ARE DEEMED NECESSARY BY THE INSPECTOR OR ENGINEER THE CONTRACTOR SHALL NOTE ON THE DRAWINGS THE APPROXIMATE LOCATION AND DESCRIPTION OF THE REPAIRS AND ADJUST THE ACTUAL QUANTITIES ENTERED INTO THE REPAIR QUANTITY TABLE.

FOR CAP AND COLUMN REPAIR DETAILS, SEE "TYPICAL CAP, COLUMN, AND RAIL REPAIR DETAILS" SHEET.



FOR SHOTCRETE REPAIRS, SEE SPECIAL PROVISIONS.

FOR EPOXY RESIN INJECTION, SEE SPECIAL PROVISIONS.

VALUES IN CHART REPRESENT ESTIMATED REPAIR TOTALS AFTER REMOVAL OF UNSOUND CONCRETE, MIN. OF 1" BEHIND REBAR AND MIN. 2" CL TO SAWCUT. SEE REPAIR DETAILS.

-  - SHOTCRETE REPAIR
- ERI - EPOXY RESIN INJECTION

PROJECT NO. I-5977
HALIFAX COUNTY
 BRIDGE NO. 12

DocuSigned by:

 AD50B1D977484CC...

 2/28/2017

STATE OF NORTH CAROLINA
 DEPARTMENT OF TRANSPORTATION
 RALEIGH
SUBSTRUCTURE
 END BENTS

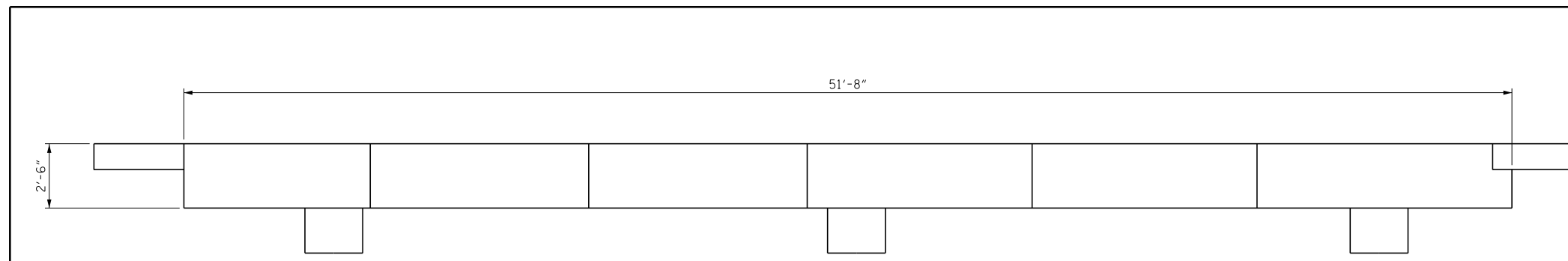
REVISIONS						SHEET NO.
NO.	BY:	DATE:	NO.	BY:	DATE:	TOTAL SHEETS
1			3			37
2			4			

DOCUMENT NOT CONSIDERED FINAL UNLESS ALL SIGNATURES COMPLETED



PLAN
END BENT 1

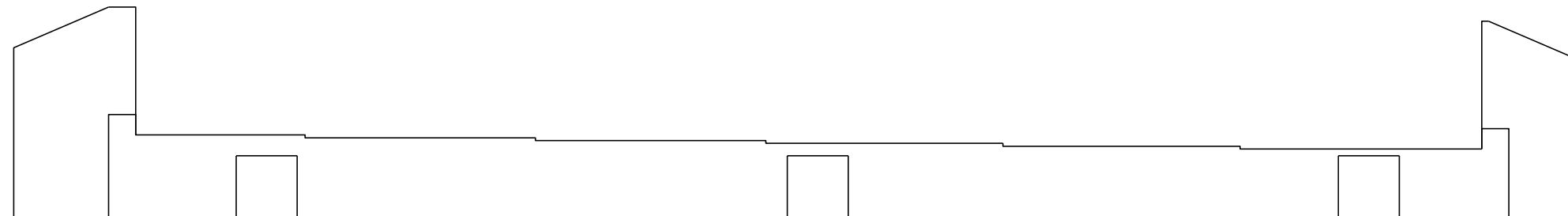

ELEVATION
END BENT 1

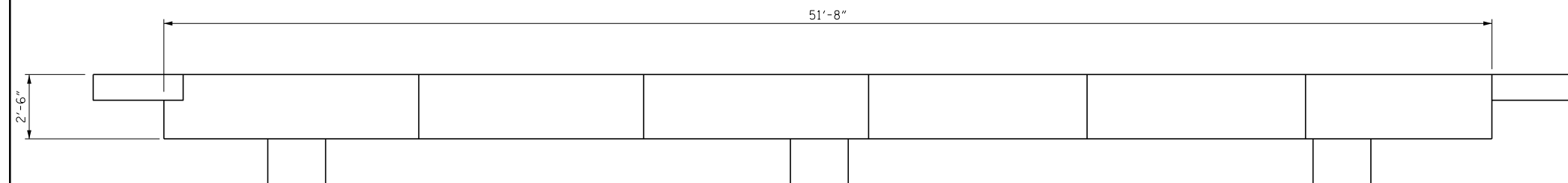

PLAN
END BENT 2

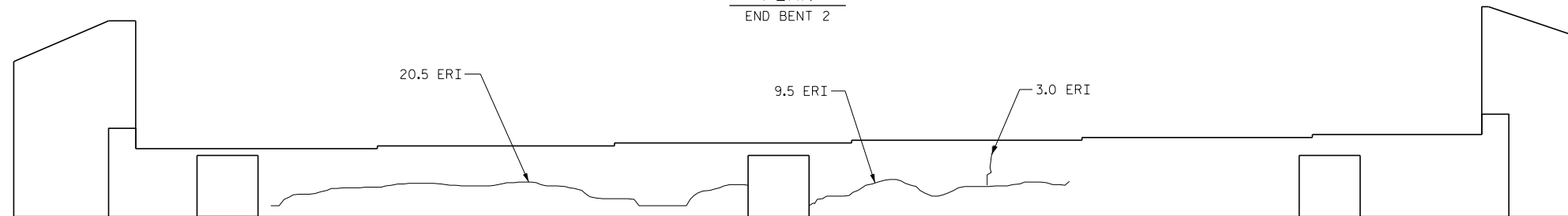

ELEVATION
END BENT 2

DRAWN BY : J. W. ARMFIELD / S. T. SANDOR DATE : 02/2017
 CHECKED BY : W. C. SMITH DATE : 02/2017

NO REPAIRS NOTED DURING INSPECTION BY STRUCTURES MANAGEMENT UNIT. THE CONTRACTOR AND ENGINEER SHALL REINSPECT THE SUBSTRUCTURE FOR POTENTIAL REPAIRS.

NOTES:

REPAIR LOCATIONS AND ESTIMATE OF QUANTITIES ARE GIVEN WITH THE BEST INFORMATION AVAILABLE. IF ADDITIONAL REPAIRS NOT SHOWN ON THE DRAWINGS ARE DEEMED NECESSARY BY THE INSPECTOR OR ENGINEER THE CONTRACTOR SHALL NOTE ON THE DRAWINGS THE APPROXIMATE LOCATION AND DESCRIPTION OF THE REPAIRS AND ADJUST THE ACTUAL QUANTITIES ENTERED INTO THE REPAIR QUANTITY TABLE.

FOR CAP AND COLUMN REPAIR DETAILS, SEE "TYPICAL CAP, COLUMN, AND RAIL REPAIR DETAILS" SHEET.

FOR SHOTCRETE REPAIRS, SEE SPECIAL PROVISIONS.

FOR EPOXY RESIN INJECTION, SEE SPECIAL PROVISIONS.

REPAIR QUANTITY TABLE

BENT 1	QUANTITIES			
	ESTIMATE		ACTUAL	
SHOTCRETE REPAIRS	AREA SF	VOLUME CF	AREA SF	VOLUME CF
CAP (VERTICAL FACE)	0.0	0.0		
CAP (HORIZONTAL, CORNER)	0.0	0.0		
COLUMN	0.0	0.0		
EPOXY RESIN INJECTION		LN. FT.		LN. FT.
CAP		0.0		
COLUMN		0.0		
EPOXY COATING	AREA SF			
TOP OF CAP	170.0			

VALUES IN CHART REPRESENT ESTIMATED REPAIR TOTALS AFTER REMOVAL OF UNSOUND CONCRETE, MIN. OF 1" BEHIND REBAR AND MIN. 2" CL TO SAWCUT. SEE REPAIR DETAILS.

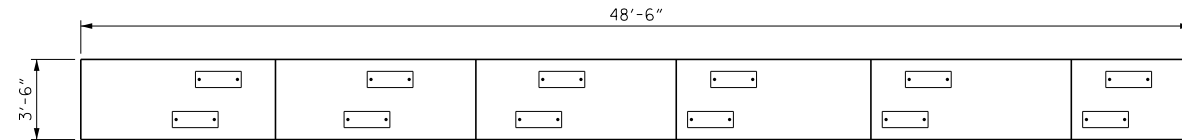

PLAN
TOP OF CAP

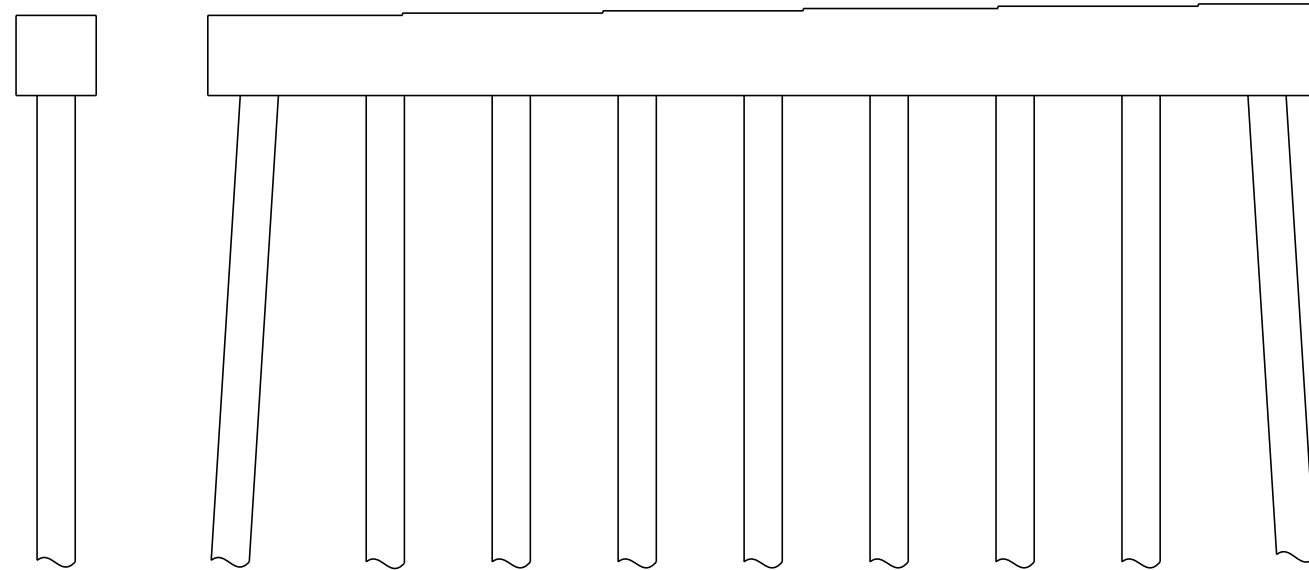

END VIEW
EAST SIDE

ELEVATION
SOUTH SIDE

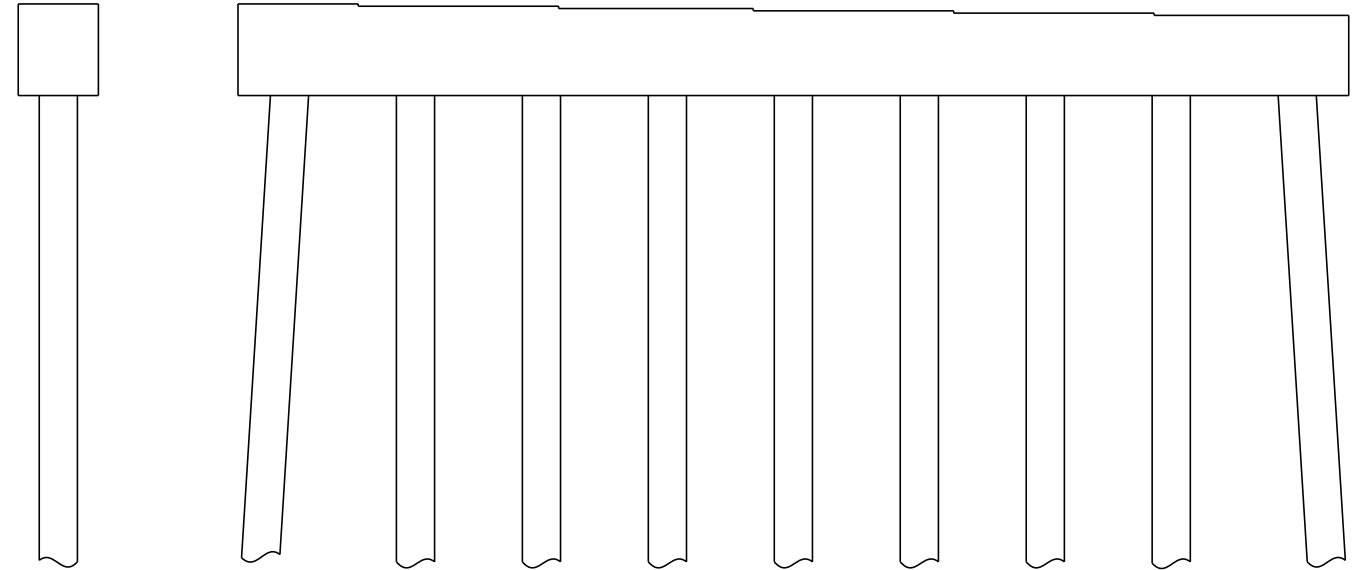

END VIEW
WEST SIDE

ELEVATION
NORTH SIDE

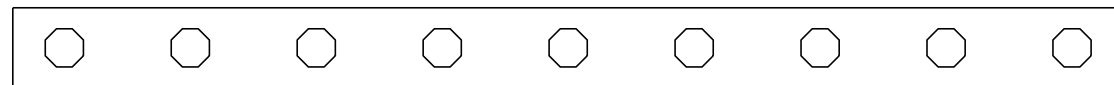

PLAN
BOTTOM OF CAP

PROJECT NO. I-5977
HALIFAX COUNTY
 BRIDGE NO. 12

- SHOTCRETE REPAIR
 - EPOXY RESIN INJECTION

DocuSigned by:

Timothy M. Sherrill
 AD50B1D977494CC...
 SEAL
 18565
 ENGINEER
 TIMOTHY M. SHERRILL

2/28/2017

STATE OF NORTH CAROLINA
 DEPARTMENT OF TRANSPORTATION
 RALEIGH

**SUBSTRUCTURE
 BENT 1**

DRAWN BY : J. W. ARMFIELD / S. T. SANDOR DATE : 02/2017
 CHECKED BY : W. M. CLARKE / W. C. SMITH DATE : 02/2017

DOCUMENT NOT CONSIDERED
 FINAL UNLESS ALL
 SIGNATURES COMPLETED

REVISIONS						SHEET NO.
NO.	BY:	DATE:	NO.	BY:	DATE:	TOTAL SHEETS
1			3			S-5
2			4			37

REPAIR QUANTITY TABLE

BENT 2	QUANTITIES			
	ESTIMATE		ACTUAL	
SHOTCRETE REPAIRS	AREA SF	VOLUME CF	AREA SF	VOLUME CF
CAP (VERTICAL FACE)	0.0	0.0		
CAP (HORIZONTAL, CORNER)	0.0	0.0		
COLUMN	0.0	0.0		
STRUT	4.0	2.0		
EPOXY RESIN INJECTION		LN. FT		LN. FT
CAP		0.0		
COLUMN		0.0		
STRUT		0.0		
EPOXY COATING	AREA SF			
TOP OF CAP	172.0			

VALUES IN CHART REPRESENT ESTIMATED REPAIR TOTALS AFTER REMOVAL OF UNSOUND CONCRETE, MIN. OF 1" BEHIND REBAR AND MIN. 2" CL TO SAWCUT. SEE REPAIR DETAILS.

NOTES:

REPAIR LOCATIONS AND ESTIMATE OF QUANTITIES ARE GIVEN WITH THE BEST INFORMATION AVAILABLE. IF ADDITIONAL REPAIRS NOT SHOWN ON THE DRAWINGS ARE DEEMED NECESSARY BY THE INSPECTOR OR ENGINEER THE CONTRACTOR SHALL NOTE ON THE DRAWINGS THE APPROXIMATE LOCATION AND DESCRIPTION OF THE REPAIRS AND ADJUST THE ACTUAL QUANTITIES ENTERED INTO THE REPAIR QUANTITY TABLE.

FOR CAP AND COLUMN REPAIR DETAILS, SEE "TYPICAL CAP, COLUMN, AND RAIL REPAIR DETAILS" SHEET.

FOR SHOTCRETE REPAIRS, SEE SPECIAL PROVISIONS.

FOR EPOXY RESIN INJECTION, SEE SPECIAL PROVISIONS.

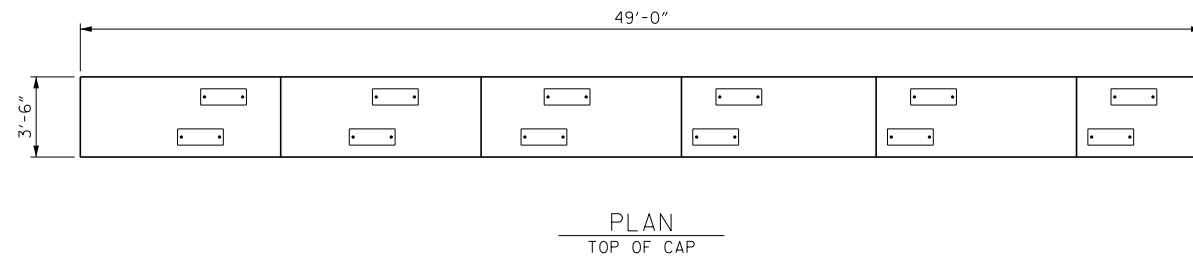

SPAN C
SPAN B

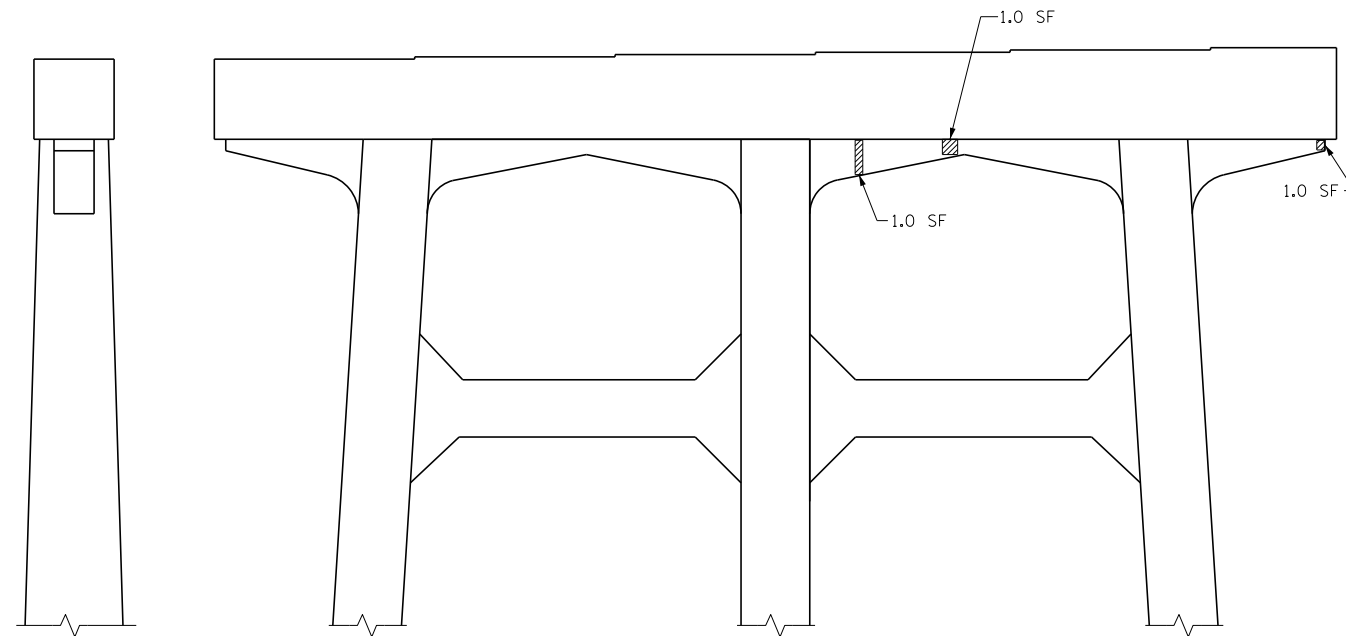

ELEVATION
SOUTH SIDE

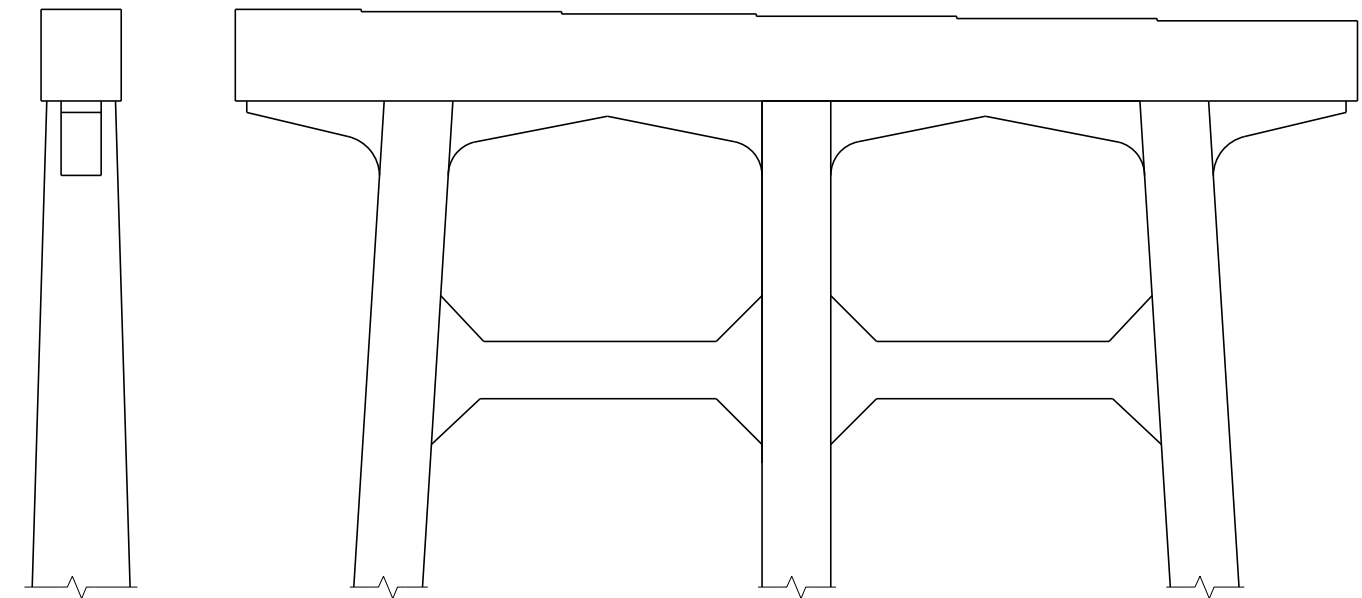

ELEVATION
NORTH SIDE

END VIEW
EAST SIDE

END VIEW
WEST SIDE

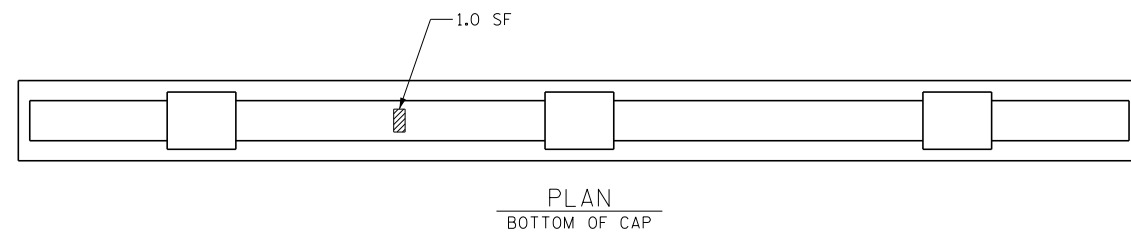

▨ - SHOTCRETE REPAIR
▨ - EPOXY RESIN INJECTION

DocuSigned by:

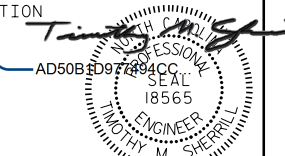

2/28/2017

PROJECT NO. I-5977
HALIFAX COUNTY
BRIDGE NO. 12

STATE OF NORTH CAROLINA
DEPARTMENT OF TRANSPORTATION
RALEIGH

SUBSTRUCTURE
BENT 2

REVISIONS

NO.	BY:	DATE:	NO.	BY:	DATE:	SHEET NO.
1			3			S-6
2			4			TOTAL SHEETS 37

DRAWN BY : J. W. ARMFIELD / S. T. SANDOR DATE : 02/2017
CHECKED BY : W. M. CLARKE / W. C. SMITH DATE : 02/2017

DOCUMENT NOT CONSIDERED
FINAL UNLESS ALL
SIGNATURES COMPLETED

REPAIR QUANTITY TABLE

BENT 3	QUANTITIES			
	ESTIMATE		ACTUAL	
SHOTCRETE REPAIRS	AREA SF	VOLUME CF	AREA SF	VOLUME CF
CAP (VERTICAL FACE)	10.0	5.0		
CAP (HORIZONTAL, CORNER)	0.0	0.0		
COLUMN	0.0	0.0		
STRUT				
EPOXY RESIN INJECTION		LN. FT		LN. FT
CAP		0.0		
COLUMN		0.0		
STRUT		1.5		
EPOXY COATING	AREA SF			
TOP OF CAP	172.0			

VALUES IN CHART REPRESENT ESTIMATED REPAIR TOTALS AFTER REMOVAL OF UNSOUND CONCRETE, MIN. OF 1" BEHIND REBAR AND MIN. 2" CL TO SAWCUT. SEE REPAIR DETAILS.

NOTES:

REPAIR LOCATIONS AND ESTIMATE OF QUANTITIES ARE GIVEN WITH THE BEST INFORMATION AVAILABLE. IF ADDITIONAL REPAIRS NOT SHOWN ON THE DRAWINGS ARE DEEMED NECESSARY BY THE INSPECTOR OR ENGINEER THE CONTRACTOR SHALL NOTE ON THE DRAWINGS THE APPROXIMATE LOCATION AND DESCRIPTION OF THE REPAIRS AND ADJUST THE ACTUAL QUANTITIES ENTERED INTO THE REPAIR QUANTITY TABLE.

FOR CAP AND COLUMN REPAIR DETAILS, SEE "TYPICAL CAP, COLUMN, AND RAIL REPAIR DETAILS" SHEET.

FOR SHOTCRETE REPAIRS, SEE SPECIAL PROVISIONS.

FOR EPOXY RESIN INJECTION, SEE SPECIAL PROVISIONS.

FOR EPOXY COATING, SEE SPECIAL PROVISIONS.

SPAN D
SPAN C

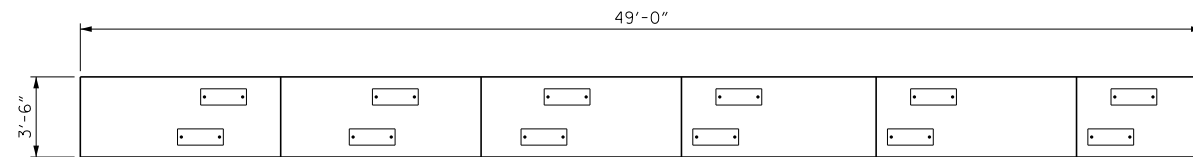

PLAN
TOP OF CAP

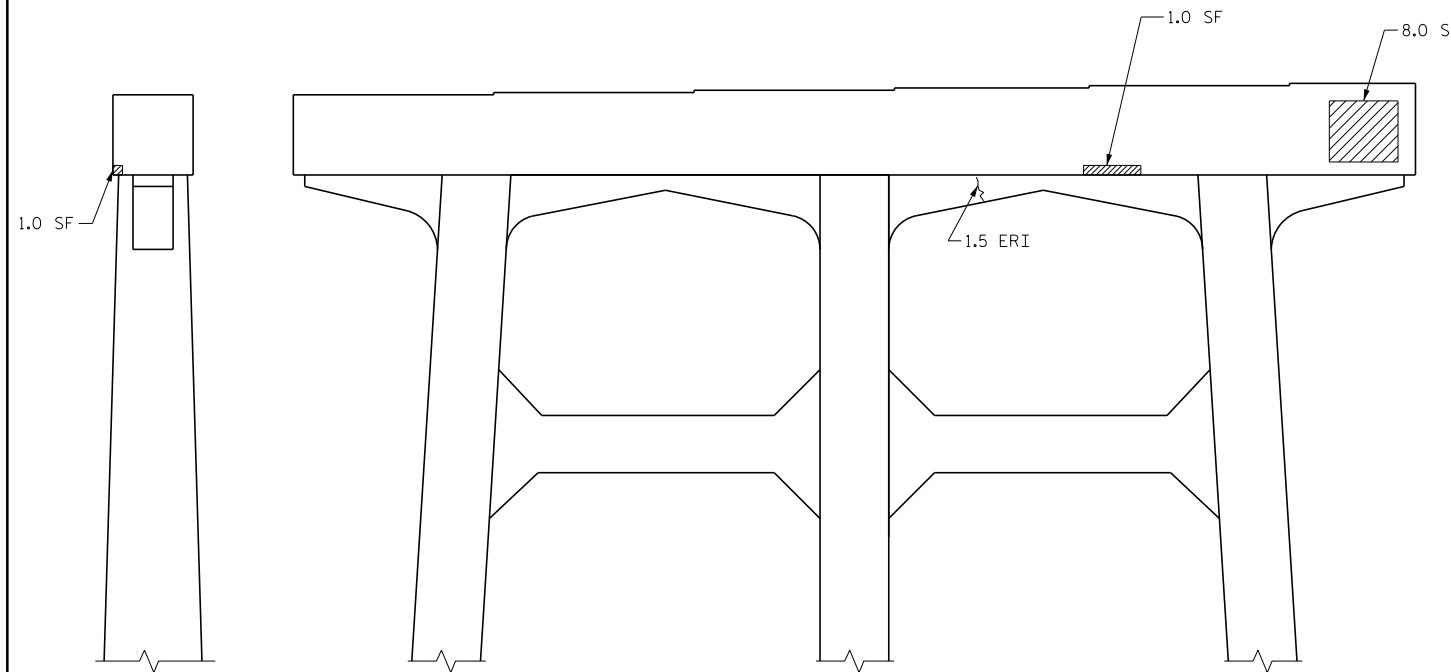

END VIEW
EAST SIDE

ELEVATION
SOUTH SIDE

END VIEW
WEST SIDE

ELEVATION
NORTH SIDE

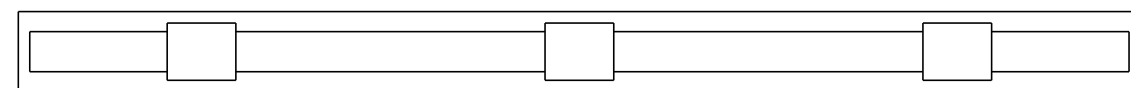

PLAN
BOTTOM OF CAP

▨ - SHOTCRETE REPAIR
ERI - EPOXY RESIN INJECTION

DocuSigned by:
Timothy M. Sherill
AD50BED97784CC
18565
ENGINEER
TIMOTHY M. SHERILL
2/28/2017

PROJECT NO. I-5977
HALIFAX COUNTY
BRIDGE NO. 12

STATE OF NORTH CAROLINA
DEPARTMENT OF TRANSPORTATION
RALEIGH
SUBSTRUCTURE
BENT 3

DRAWN BY : J. W. ARMFIELD / S. T. SANDOR DATE : 02/2017
CHECKED BY : W. M. CLARKE / W. C. SMITH DATE : 02/2017

DOCUMENT NOT CONSIDERED
FINAL UNLESS ALL
SIGNATURES COMPLETED

REVISIONS						SHEET NO.
NO.	BY:	DATE:	NO.	BY:	DATE:	S-7
1			3			TOTAL SHEETS
2			4			37

NOTES:

REPAIR LOCATIONS AND ESTIMATE OF QUANTITIES ARE GIVEN WITH THE BEST INFORMATION AVAILABLE. IF ADDITIONAL REPAIRS NOT SHOWN ON THE DRAWINGS ARE DEEMED NECESSARY BY THE INSPECTOR OR ENGINEER THE CONTRACTOR SHALL NOTE ON THE DRAWINGS THE APPROXIMATE LOCATION AND DESCRIPTION OF THE REPAIRS AND ADJUST THE ACTUAL QUANTITIES ENTERED INTO THE REPAIR QUANTITY TABLE.

FOR CAP AND COLUMN REPAIR DETAILS, SEE "TYPICAL CAP, COLUMN, AND RAIL REPAIR DETAILS" SHEET.

FOR SHOTCRETE REPAIRS, SEE SPECIAL PROVISIONS.

FOR EPOXY RESIN INJECTION, SEE SPECIAL PROVISIONS.

REPAIR QUANTITY TABLE

BENT 4	QUANTITIES			
	ESTIMATE		ACTUAL	
SHOTCRETE REPAIRS	AREA SF	VOLUME CF	AREA SF	VOLUME CF
CAP (VERTICAL FACE)	12.0	6.0		
CAP (HORIZONTAL, CORNER)	0.0	0.0		
COLUMN	0.0	0.0		
EPOXY RESIN INJECTION		LN. FT.		LN. FT.
CAP		3.0		
COLUMN		0.0		
EPOXY COATING	AREA SF			
TOP OF CAP	170.0			

VALUES IN CHART REPRESENT ESTIMATED REPAIR TOTALS AFTER REMOVAL OF UNSOUND CONCRETE, MIN. OF 1" BEHIND REBAR AND MIN. 2" CL TO SAWCUT. SEE REPAIR DETAILS.

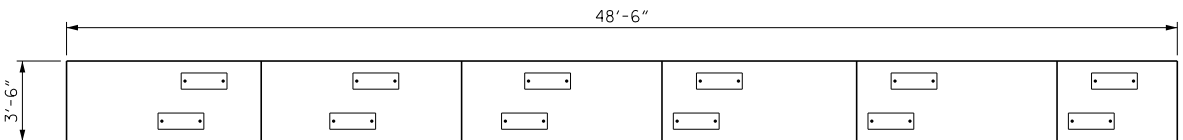

SPAN E
SPAN D

PLAN
TOP OF CAP

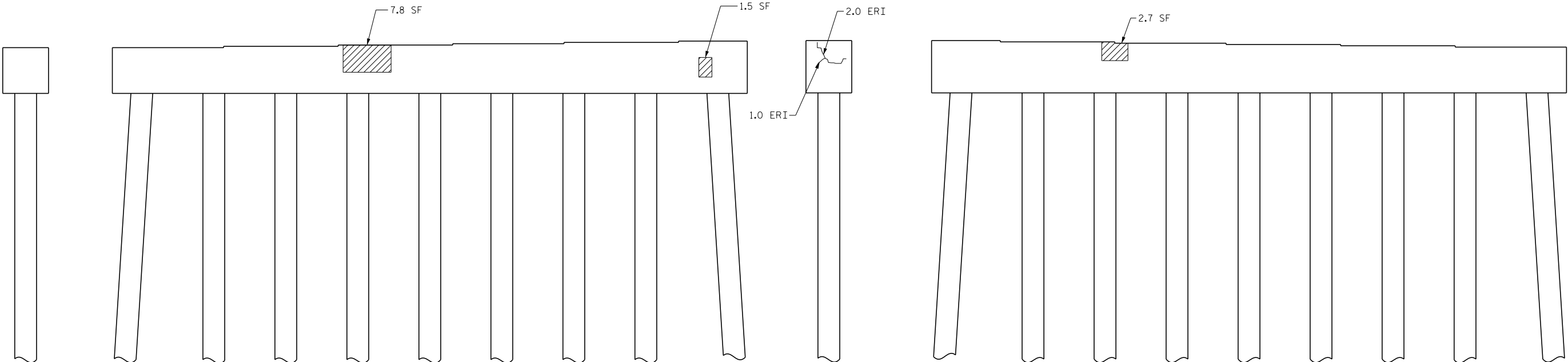

END VIEW
EAST SIDE

ELEVATION
SOUTH SIDE

END VIEW
WEST SIDE

ELEVATION
NORTH SIDE

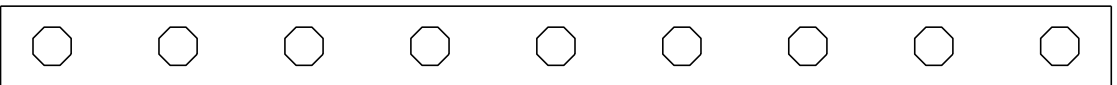

PLAN
BOTTOM OF CAP

▨ - SHOTCRETE REPAIR
ERI - EPOXY RESIN INJECTION

DocuSigned by:
Timothy M. Sherill
AD50BED97784CC
18565
PROFESSIONAL ENGINEER
TIMOTHY M. SHERILL
2/28/2017

PROJECT NO. I-5977
HALIFAX COUNTY
BRIDGE NO. 12

STATE OF NORTH CAROLINA
DEPARTMENT OF TRANSPORTATION
RALEIGH
SUBSTRUCTURE
BENT 4

DRAWN BY : J. W. ARMFIELD / S. T. SANDOR DATE : 02/2017
CHECKED BY : W. M. CLARKE / W. C. SMITH DATE : 02/2017

REVISIONS						SHEET NO.
NO.	BY:	DATE:	NO.	BY:	DATE:	TOTAL SHEETS
1			3			8
2			4			37

DOCUMENT NOT CONSIDERED
FINAL UNLESS ALL
SIGNATURES COMPLETED

REPAIR QUANTITY TABLE

END BENT 1	QUANTITIES			
	ESTIMATE		ACTUAL	
SHOTCRETE REPAIRS	AREA SF	VOLUME CF	AREA SF	VOLUME CF
CAP (VERTICAL FACE)	4.5	2.3		
CAP (HORIZONTAL, CORNER)	0.0	0.0		
EPOXY RESIN INJECTION		LN. FT.	LN. FT.	
CAP		3.0		
EPOXY COATING		AREA SF		
TOP OF CAP		142.0		
END BENT 2	QUANTITIES			
	ESTIMATE		ACTUAL	
SHOTCRETE REPAIRS	AREA SF	VOLUME CF	AREA SF	VOLUME CF
CAP (VERTICAL FACE)	0.0	0.0		
CAP (HORIZONTAL, CORNER)	0.0	0.0		
EPOXY RESIN INJECTION		LN. FT.	LN. FT.	
CAP		2.0		
EPOXY COATING		AREA SF		
TOP OF CAP		142.0		

NOTES:

REPAIR LOCATIONS AND ESTIMATE OF QUANTITIES ARE GIVEN WITH THE BEST INFORMATION AVAILABLE. IF ADDITIONAL REPAIRS NOT SHOWN ON THE DRAWINGS ARE DEEMED NECESSARY BY THE INSPECTOR OR ENGINEER THE CONTRACTOR SHALL NOTE ON THE DRAWINGS THE APPROXIMATE LOCATION AND DESCRIPTION OF THE REPAIRS AND ADJUST THE ACTUAL QUANTITIES ENTERED INTO THE REPAIR QUANTITY TABLE.

FOR CAP AND COLUMN REPAIR DETAILS, SEE "TYPICAL CAP, COLUMN, AND RAIL REPAIR DETAILS" SHEET.

FOR SHOTCRETE REPAIRS, SEE SPECIAL PROVISIONS.

FOR EPOXY RESIN INJECTION, SEE SPECIAL PROVISIONS.

VALUES IN CHART REPRESENT ESTIMATED REPAIR TOTALS AFTER REMOVAL OF UNSOUND CONCRETE, MIN. OF 1" BEHIND REBAR AND MIN. 2" CL TO SAWCUT. SEE REPAIR DETAILS.

 - SHOTCRETE REPAIR

ERI - EPOXY RESIN INJECTION

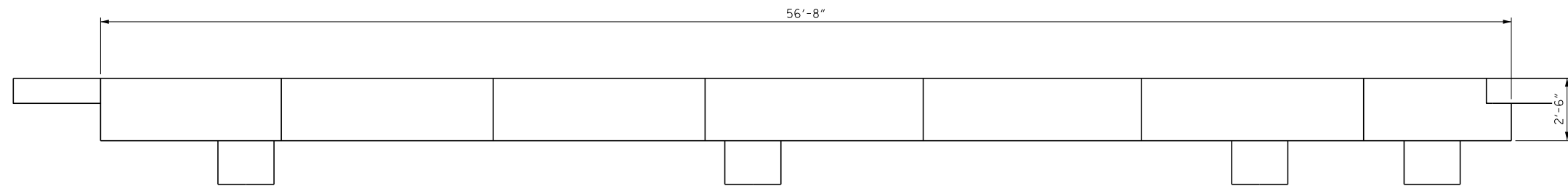

PLAN
END BENT 1

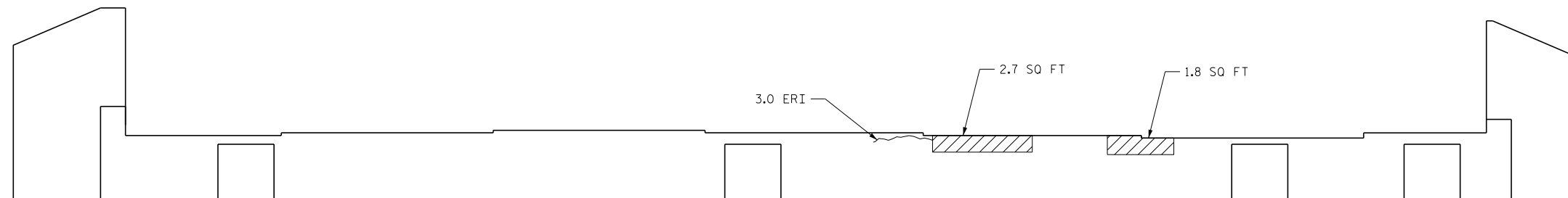

ELEVATION
END BENT 1

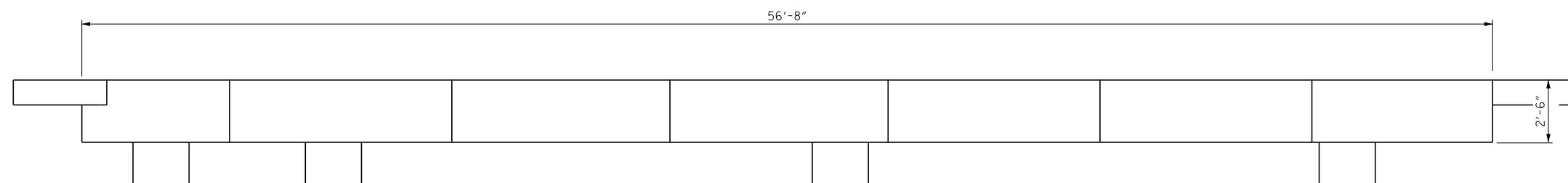

PLAN
END BENT 2

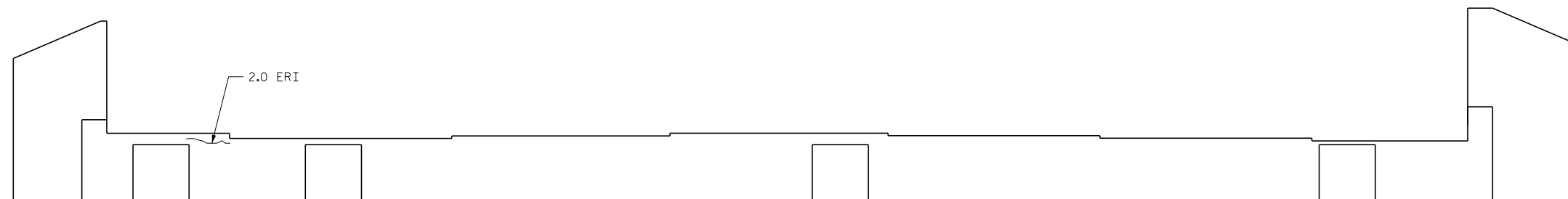

ELEVATION
END BENT 2

PROJECT NO. I-5977

HALIFAX COUNTY

BRIDGE NO. 13

DocuSigned by:

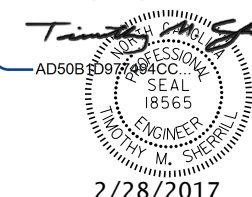

2/28/2017

STATE OF NORTH CAROLINA
DEPARTMENT OF TRANSPORTATION
RALEIGH

**SUBSTRUCTURE
END BENTS**

DRAWN BY : J. W. ARMFIELD / S. T. SANDOR DATE : 02/2017
CHECKED BY : W. M. CLARKE / W. C. SMITH DATE : 02/2017

27-FEB-2017 14:19
R:\Structures\I5977 DGN\402_021_I5977_SMU_S9_EB1.2.DGN
wsmith

REVISIONS						SHEET NO.
NO.	BY:	DATE:	NO.	BY:	DATE:	TOTAL SHEETS
1			3			37
2			4			

DOCUMENT NOT CONSIDERED
FINAL UNLESS ALL
SIGNATURES COMPLETED

REPAIR QUANTITY TABLE

REPAIRS BENT 1	QUANTITIES			
	ESTIMATE		ACTUAL	
SHOTCRETE REPAIRS	AREA SF	VOLUME CF	AREA SF	VOLUME CF
CAP (VERTICAL FACE)	2.0	1.0		
CAP (HORIZONTAL, CORNER)	0.0	0.0		
COLUMN	0.0	0.0		
EPOXY RESIN INJECTION		LN. FT.		LN. FT.
CAP		7.5		
COLUMN		0.0		
EPOXY COATING	AREA SF			
TOP OF CAP	179.0			

VALUES IN CHART REPRESENT ESTIMATED REPAIR TOTALS AFTER REMOVAL OF UNSOUND CONCRETE, MIN. OF 1" BEHIND REBAR AND MIN. 2" CL TO SAWCUT. SEE REPAIR DETAILS.

NOTES:

REPAIR LOCATIONS AND ESTIMATE OF QUANTITIES ARE GIVEN WITH THE BEST INFORMATION AVAILABLE. IF ADDITIONAL REPAIRS NOT SHOWN ON THE DRAWINGS ARE DEEMED NECESSARY BY THE INSPECTOR OR ENGINEER THE CONTRACTOR SHALL NOTE ON THE DRAWINGS THE APPROXIMATE LOCATION AND DESCRIPTION OF THE REPAIRS AND ADJUST THE ACTUAL QUANTITIES ENTERED INTO THE REPAIR QUANTITY TABLE.

FOR CAP AND COLUMN REPAIR DETAILS, SEE "TYPICAL CAP, COLUMN, AND RAIL REPAIR DETAILS" SHEET.

FOR SHOTCRETE REPAIRS, SEE SPECIAL PROVISIONS.

FOR EPOXY RESIN INJECTION, SEE SPECIAL PROVISIONS.

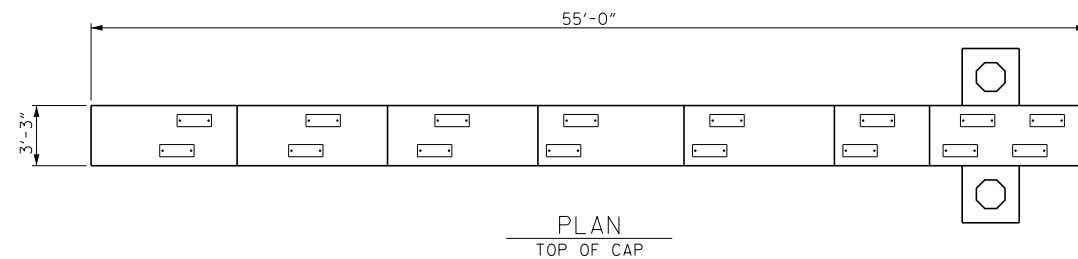

SPAN B
SPAN A

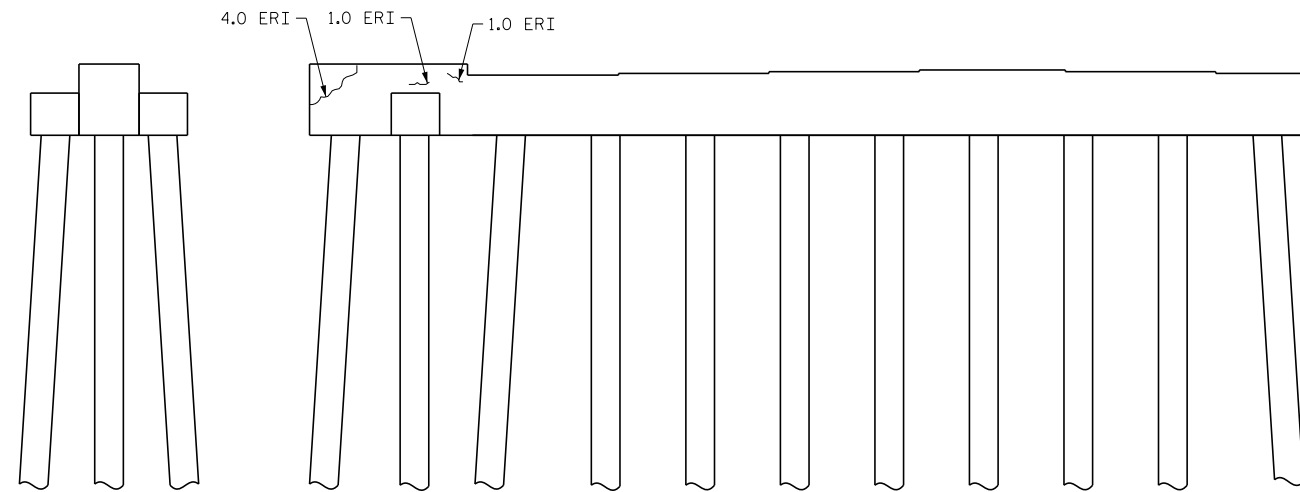
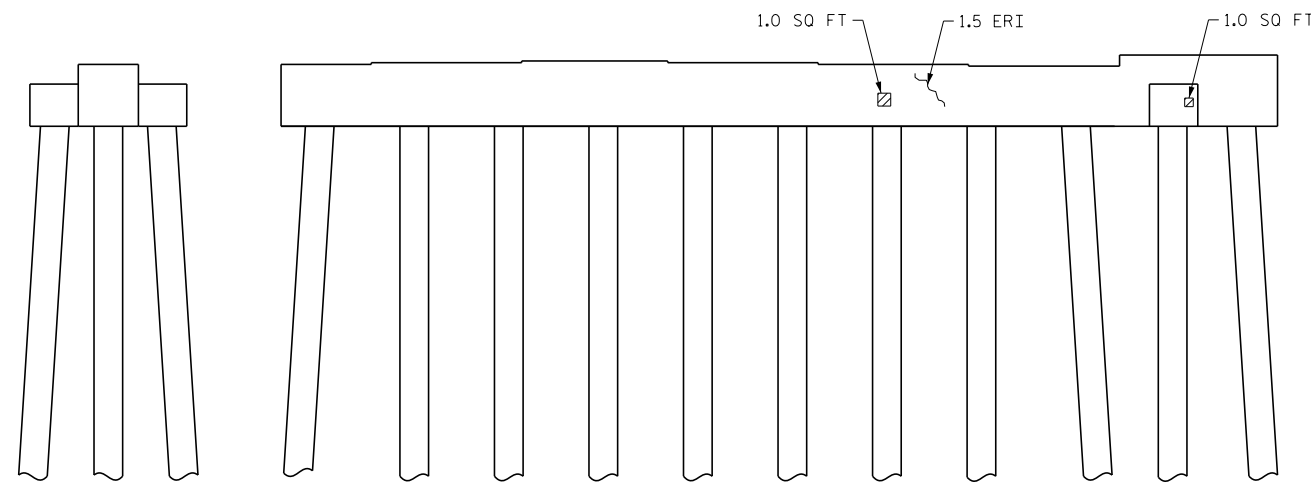

END VIEW
EAST SIDE

ELEVATION
NORTH SIDE

END VIEW
WEST SIDE

ELEVATION
SOUTH SIDE

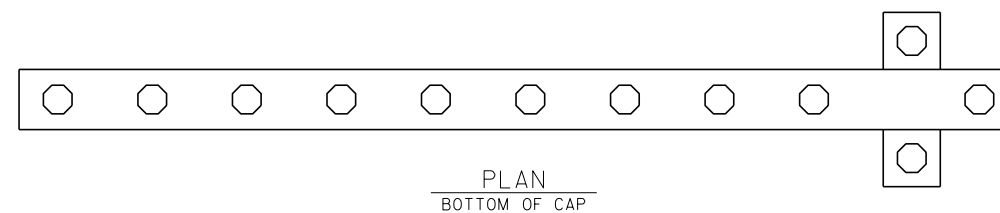

PLAN
BOTTOM OF CAP

PROJECT NO. I-5977
HALIFAX COUNTY
BRIDGE NO. 13

▨ - SHOTCRETE REPAIR
ERI - EPOXY RESIN INJECTION

DocuSigned by:

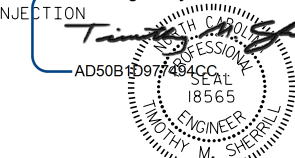

2/28/2017

STATE OF NORTH CAROLINA
DEPARTMENT OF TRANSPORTATION
RALEIGH

SUBSTRUCTURE
BENT 1

DRAWN BY : J. W. ARMFIELD / S. T. SANDOR DATE : 02/2017
CHECKED BY : W. M. CLARKE / W. C. SMITH DATE : 02/2017

DOCUMENT NOT CONSIDERED
FINAL UNLESS ALL
SIGNATURES COMPLETED

REVISIONS						SHEET NO.
NO.	BY:	DATE:	NO.	BY:	DATE:	TOTAL SHEETS
1			3			37
2			4			

REPAIR QUANTITY TABLE

BENT 2	QUANTITIES			
	ESTIMATE		ACTUAL	
SHOTCRETE REPAIRS	AREA SF	VOLUME CF	AREA SF	VOLUME CF
CAP (VERTICAL FACE)	2.0	1.0		
CAP (HORIZONTAL, CORNER)	7.4	3.7		
COLUMN	1.3	0.7		
STRUT	15.6	7.8		
EPOXY RESIN INJECTION		LN. FT.	LN. FT.	
CAP		51.0		
COLUMN		0.0		
EPOXY COATING		AREA SF		
TOP OF CAP		179.0		

VALUES IN CHART REPRESENT ESTIMATED REPAIR TOTALS AFTER REMOVAL OF UNSOUND CONCRETE, MIN. OF 1" BEHIND REBAR AND MIN. 2" CL TO SAWCUT. SEE REPAIR DETAILS.

NOTES:

REPAIR LOCATIONS AND ESTIMATE OF QUANTITIES ARE GIVEN WITH THE BEST INFORMATION AVAILABLE. IF ADDITIONAL REPAIRS NOT SHOWN ON THE DRAWINGS ARE DEEMED NECESSARY BY THE INSPECTOR OR ENGINEER THE CONTRACTOR SHALL NOTE ON THE DRAWINGS THE APPROXIMATE LOCATION AND DESCRIPTION OF THE REPAIRS AND ADJUST THE ACTUAL QUANTITIES ENTERED INTO THE REPAIR QUANTITY TABLE.

FOR CAP AND COLUMN REPAIR DETAILS, SEE "TYPICAL CAP, COLUMN, AND RAIL REPAIR DETAILS" SHEET.

FOR SHOTCRETE REPAIRS, SEE SPECIAL PROVISIONS.

FOR EPOXY RESIN INJECTION, SEE SPECIAL PROVISIONS.

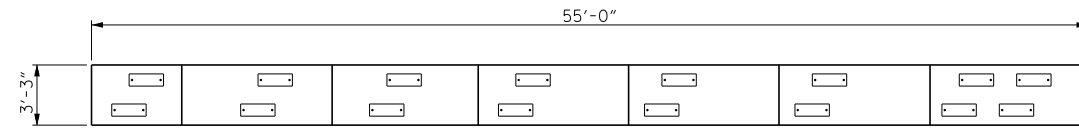

PLAN
TOP OF CAP

SPAN C
SPAN B

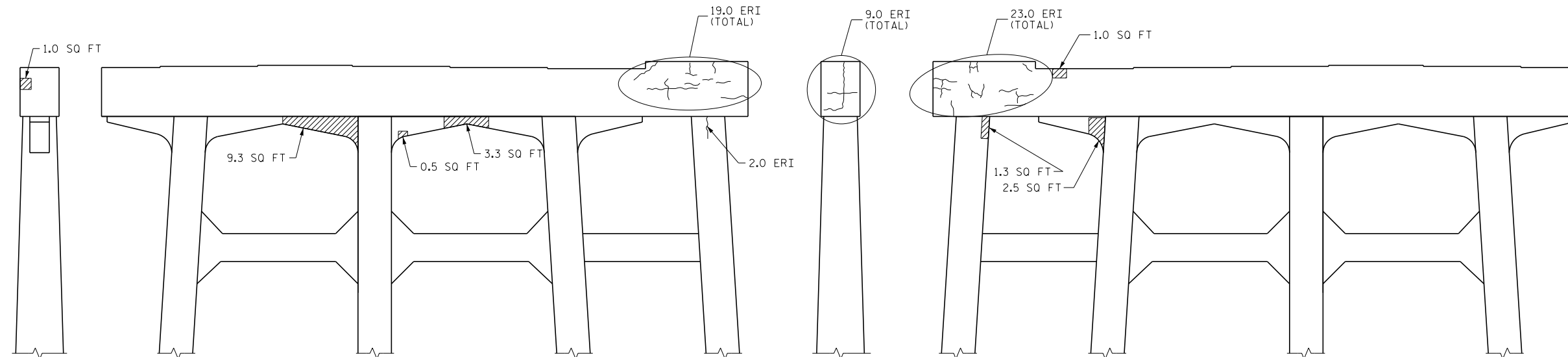

END VIEW
EAST SIDE

ELEVATION
NORTH SIDE

END VIEW
WEST SIDE

ELEVATION
SOUTH SIDE

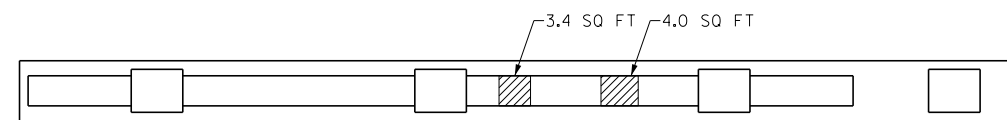

PLAN
BOTTOM OF CAP

PROJECT NO. I-5977
HALIFAX COUNTY
BRIDGE NO. 13

▨ - SHOTCRETE REPAIR
ERI - EPOXY RESIN INJECTION

DocuSigned by:
Timothy M. Serrill
AD50B1D9778946C
18565
PROFESSIONAL
ENGINEER
TIMOTHY M. SERRILL

2/28/2017

STATE OF NORTH CAROLINA
DEPARTMENT OF TRANSPORTATION
RALEIGH

SUBSTRUCTURE
BENT 2

DRAWN BY : J. W. ARMFIELD / S. T. SANDOR DATE : 02/2017
CHECKED BY : W. M. CLARKE / W. C. SMITH DATE : 02/2017

DOCUMENT NOT CONSIDERED
FINAL UNLESS ALL
SIGNATURES COMPLETED

REVISIONS						SHEET NO.
NO.	BY:	DATE:	NO.	BY:	DATE:	S-11
1			3			TOTAL SHEETS
2			4			37

REPAIR QUANTITY TABLE

REPAIRS BENT 3	QUANTITIES			
	ESTIMATE		ACTUAL	
SHOTCRETE REPAIRS	AREA SF	VOLUME CF	AREA SF	VOLUME CF
CAP (VERTICAL FACE)	1.0	0.5		
CAP (HORIZONTAL, CORNER)	9.0	4.5		
COLUMN	0.0	0.0		
STRUT	7.6	3.8		
EPOXY RESIN INJECTION		LN. FT.		LN. FT.
CAP		34.0		
COLUMN		0.0		
EPOXY COATING		AREA SF		
TOP OF CAP		179.0		

VALUES IN CHART REPRESENT ESTIMATED REPAIR TOTALS AFTER REMOVAL OF UNSOUND CONCRETE, MIN. OF 1" BEHIND REBAR AND MIN. 2" CL TO SAWCUT. SEE REPAIR DETAILS.

NOTES:

REPAIR LOCATIONS AND ESTIMATE OF QUANTITIES ARE GIVEN WITH THE BEST INFORMATION AVAILABLE. IF ADDITIONAL REPAIRS NOT SHOWN ON THE DRAWINGS ARE DEEMED NECESSARY BY THE INSPECTOR OR ENGINEER THE CONTRACTOR SHALL NOTE ON THE DRAWINGS THE APPROXIMATE LOCATION AND DESCRIPTION OF THE REPAIRS AND ADJUST THE ACTUAL QUANTITIES ENTERED INTO THE REPAIR QUANTITY TABLE.

FOR CAP AND COLUMN REPAIR DETAILS, SEE "TYPICAL CAP, COLUMN, AND RAIL REPAIR DETAILS" SHEET.

FOR SHOTCRETE REPAIRS, SEE SPECIAL PROVISIONS.

FOR EPOXY RESIN INJECTION, SEE SPECIAL PROVISIONS.

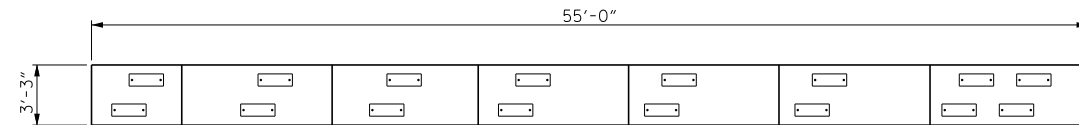

PLAN
TOP OF CAP

SPAN D
SPAN C

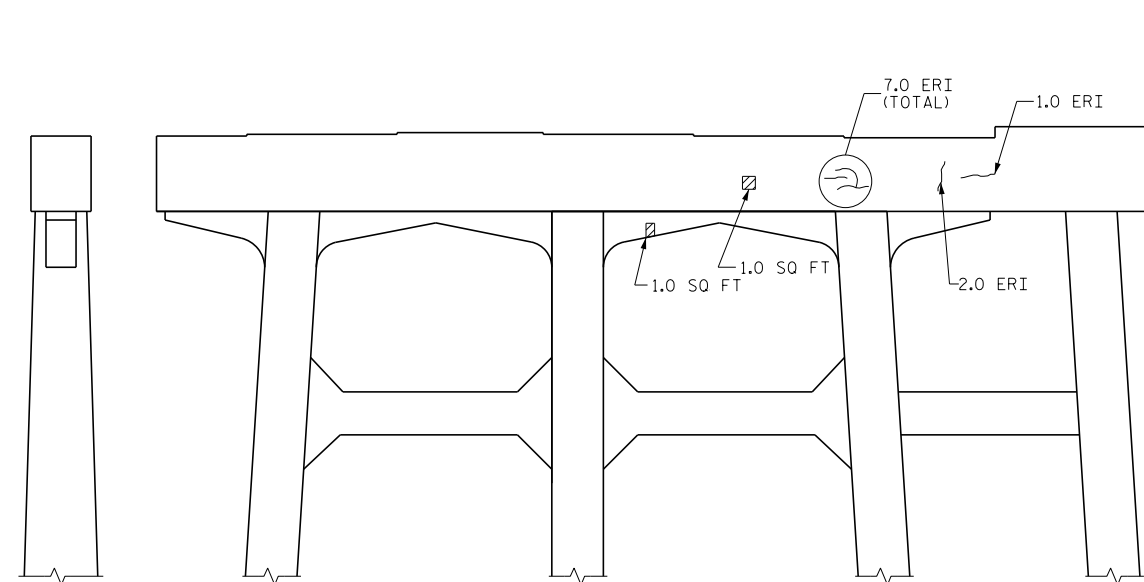

ELEVATION
NORTH SIDE

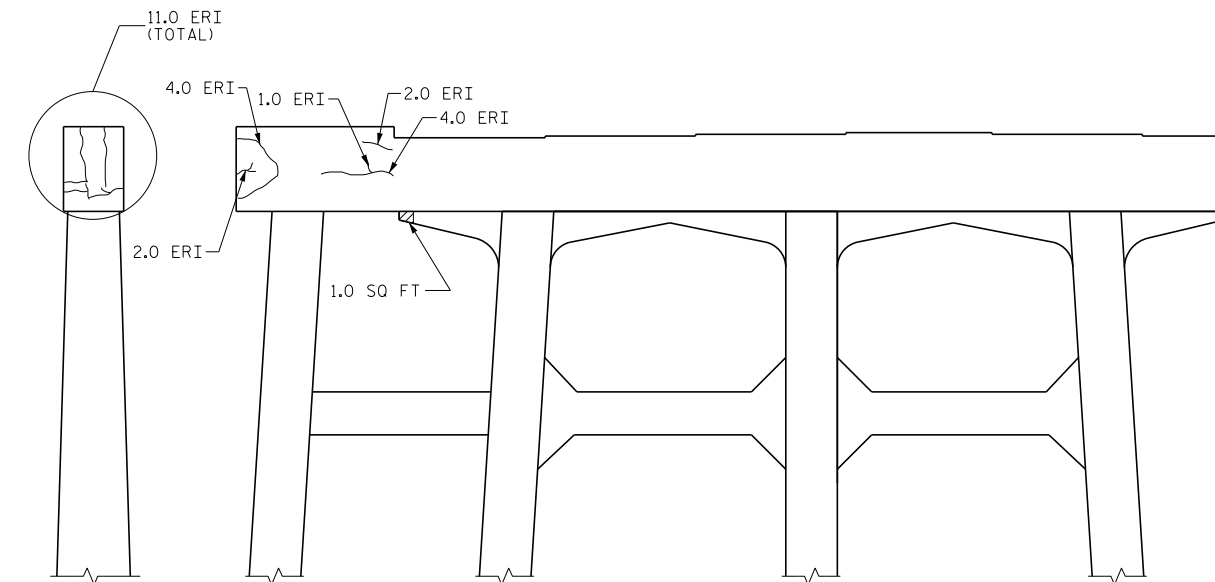

ELEVATION
SOUTH SIDE

END VIEW
EAST SIDE

END VIEW
WEST SIDE

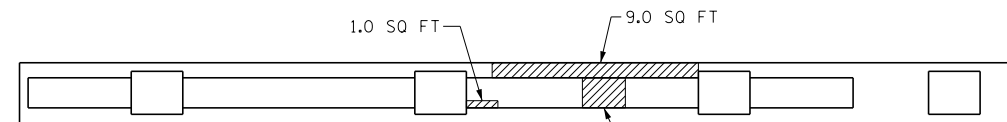

PLAN
BOTTOM OF CAP

PROJECT NO. I-5977
HALIFAX COUNTY
BRIDGE NO. 13

▨ - SHOTCRETE REPAIR
ERI - EPOXY RESIN INJECTION

DocuSigned by:

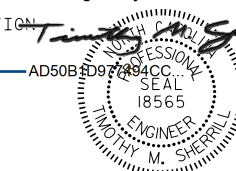

2/28/2017

STATE OF NORTH CAROLINA
DEPARTMENT OF TRANSPORTATION
RALEIGH

SUBSTRUCTURE
BENT 3

DRAWN BY : J. W. ARMFIELD / S. T. SANDOR DATE : 02/2017
CHECKED BY : W. M. CLARKE / W. C. SMITH DATE : 02/2017

DOCUMENT NOT CONSIDERED
FINAL UNLESS ALL
SIGNATURES COMPLETED

REVISIONS						SHEET NO.
NO.	BY:	DATE:	NO.	BY:	DATE:	TOTAL SHEETS
1			3			37
2			4			

REPAIR QUANTITY TABLE

REPAIRS BENT 4	QUANTITIES			
	ESTIMATE		ACTUAL	
SHOTCRETE REPAIRS	AREA SF	VOLUME CF	AREA SF	VOLUME CF
CAP (VERTICAL FACE)	10.3	5.2		
CAP (HORIZONTAL, CORNER)	5.8	2.9		
COLUMN	0.0	0.0		
EPOXY RESIN INJECTION		LN. FT.		LN. FT.
CAP		2.0		
COLUMN		0.0		
EPOXY COATING				
TOP OF CAP	179.0			

VALUES IN CHART REPRESENT ESTIMATED REPAIR TOTALS AFTER REMOVAL OF UNSOUND CONCRETE, MIN. OF 1" BEHIND REBAR AND MIN. 2" CL TO SAWCUT. SEE REPAIR DETAILS.

NOTES:

REPAIR LOCATIONS AND ESTIMATE OF QUANTITIES ARE GIVEN WITH THE BEST INFORMATION AVAILABLE. IF ADDITIONAL REPAIRS NOT SHOWN ON THE DRAWINGS ARE DEEMED NECESSARY BY THE INSPECTOR OR ENGINEER THE CONTRACTOR SHALL NOTE ON THE DRAWINGS THE APPROXIMATE LOCATION AND DESCRIPTION OF THE REPAIRS AND ADJUST THE ACTUAL QUANTITIES ENTERED INTO THE REPAIR QUANTITY TABLE.

FOR CAP AND COLUMN REPAIR DETAILS, SEE "TYPICAL CAP, COLUMN, AND RAIL REPAIR DETAILS" SHEET.

FOR SHOTCRETE REPAIRS, SEE SPECIAL PROVISIONS.

FOR EPOXY RESIN INJECTION, SEE SPECIAL PROVISIONS.

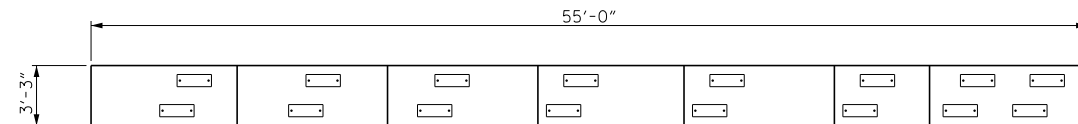

PLAN
TOP OF CAP

SPAN E
SPAN D

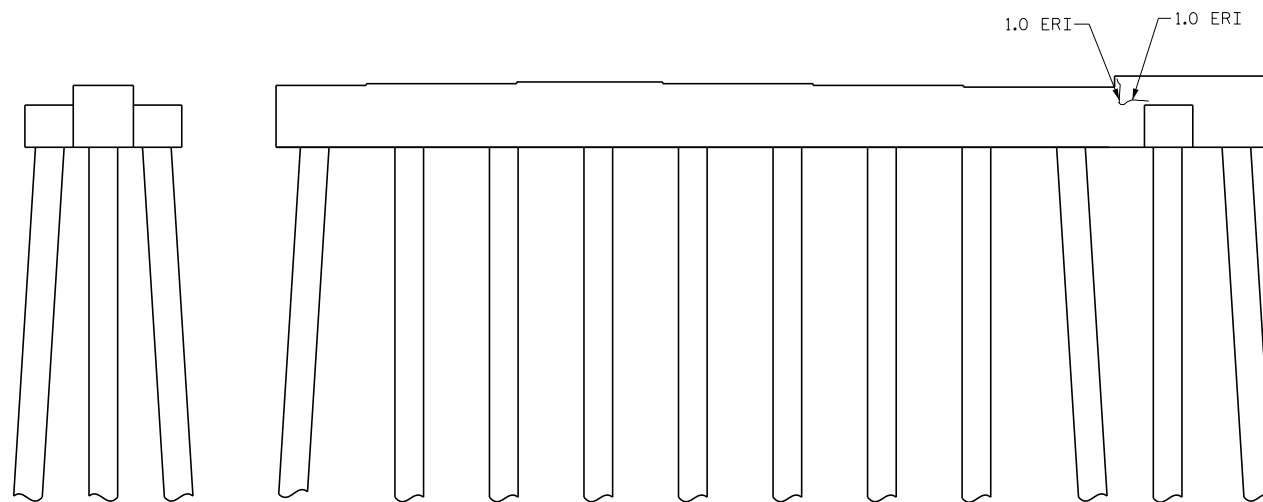

END VIEW
EAST SIDE

ELEVATION
NORTH SIDE

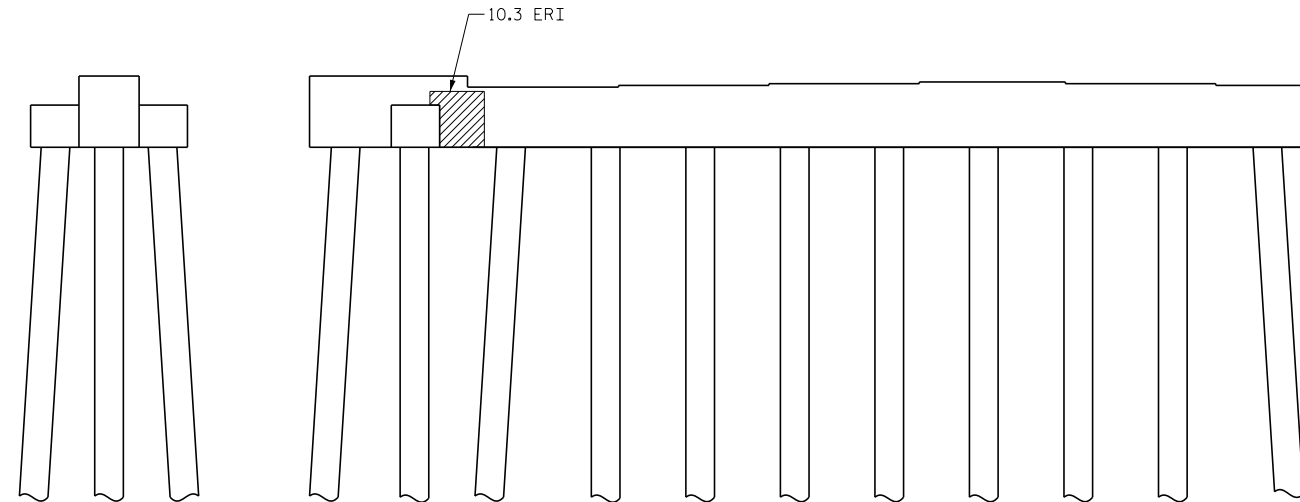

END VIEW
WEST SIDE

ELEVATION
SOUTH SIDE

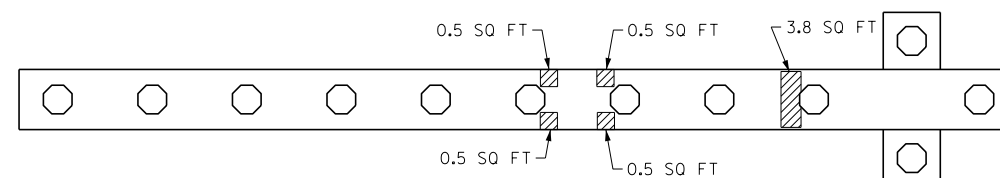

PLAN
BOTTOM OF CAP

PROJECT NO. I-5977
HALIFAX COUNTY
BRIDGE NO. 13

▨ - SHOTCRETE REPAIR
ERI - EPOXY RESIN INJECTION

DocuSigned by:
Timothy M. Sheppard
AD50B1D977@ACC
PROFESSIONAL
SEAL
18565
ENGINEER
TIMOTHY M. SHEPPARD
2/28/2017

STATE OF NORTH CAROLINA
DEPARTMENT OF TRANSPORTATION
RALEIGH
SUBSTRUCTURE
BENT 4

DRAWN BY : J. W. ARMFIELD / S. T. SANDOR DATE : 02/2017
CHECKED BY : W. M. CLARKE / W. C. SMITH DATE : 02/2017

DOCUMENT NOT CONSIDERED
FINAL UNLESS ALL
SIGNATURES COMPLETED

REVISIONS						SHEET NO.
NO.	BY:	DATE:	NO.	BY:	DATE:	TOTAL SHEETS
1			3			37
2			4			

RAIL REPAIR TABLE			
SPAN	RAIL	LOCATION	REPAIR SIZE
A	LEFT RAIL	INSIDE FACE OF RAIL @ 6' FROM END BENT 1	4.0 SQ FT
A	LEFT RAIL	INSIDE FACE OF RAIL @ 2' FROM BENT 1	0.5 SQ FT
B	LEFT RAIL	INSIDE FACE OF RAIL @ 10' FROM BENT 1	2.0 SQ FT
C	LEFT RAIL	INSIDE FACE OF RAIL @ 2' FROM BENT 2	2.0 SQ FT
C	LEFT RAIL	INSIDE FACE OF RAIL @ 5' FROM BENT 3	1.0 SQ FT
A	RIGHT RAIL	INSIDE FACE OF RAIL @ 10' FROM END BENT 1	3.0' ERI
B	RIGHT RAIL	INSIDE FACE OF RAIL @ 25' FROM BENT 1	0.5 SQ FT
B	RIGHT RAIL	INSIDE FACE OF RAIL @ 30' FROM BENT 1	2.0 SQ FT
C - E	RIGHT RAIL	MULTIPLE 0.2 SQ FT LOCATIONS	10 SQ FT TOTAL

UNDERDECK & DIAPHRAGM REPAIR TABLE			
SPAN	BAY	LOCATION	REPAIR SIZE
B	1	BOTTOM OF DIAPHRAGM AT BENT 2	4.0 SQ FT
B	2	BOTTOM OF DIAPHRAGM AT BENT 2	0.3 SQ FT
B	3	BOTTOM OF DIAPHRAGM AT BENT 2 (NEAR GIRDER 3)	0.7 SQ FT
B	3	BOTTOM OF DIAPHRAGM AT BENT 2 (NEAR GIRDER 4)	0.7 SQ FT
D	3	BOTTOM OF DIAPHRAGM AT BENT 3	3.2 SQ FT
D	2	BOTTOM OF DIAPHRAGM AT BENT 3 (NEAR GIRDER 3)	1.7 SQ FT
D	2	BOTTOM OF DIAPHRAGM AT BENT 3 (NEAR GIRDER 2 SIDE)	1.3 SQ FT
E	2	BOTTOM OF DIAPHRAGM AT BENT 5	1.5 SQ FT

REPAIR QUANTITY TABLE				
	QUANTITIES			
	ESTIMATE		ACTUAL	
SHOTCRETE REPAIRS	AREA SF	VOLUME CF	AREA SF	VOLUME CF
RAIL	22.0	11.0		
DIAPHRAGM	13.4	6.7		
EPOXY RESIN INJECTION		LN. FT.		LN. FT.
RAIL		3.0		
DIAPHRAGM		0.0		

VALUES IN CHART REPRESENT ESTIMATED REPAIR TOTALS AFTER REMOVAL OF UNSOUND CONCRETE, MIN. OF 1" BEHIND REBAR AND MIN. 2" CL TO SAWCUT. SEE REPAIR DETAILS.

NOTES:

FOR CAP, COLUMN, AND RAIL REPAIR DETAILS, SEE "TYPICAL CAP, COLUMN, AND RAIL REPAIR DETAILS" SHEET.

FOR SHOTCRETE REPAIRS, SEE SPECIAL PROVISIONS.

FOR EPOXY RESIN INJECTION, SEE SPECIAL PROVISIONS.

FOR GIRDER REPAIR DETAILS, SEE "GIRDER REPAIR DETAILS" SHEET.

PROJECT NO. I-5977
HALIFAX COUNTY
 BRIDGE NO. 12

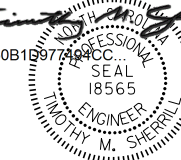
DocuSigned by:

 AD50B1B977A9CC...

 2/28/2017

STATE OF NORTH CAROLINA
 DEPARTMENT OF TRANSPORTATION
 RALEIGH
SHOTCRETE REPAIR & CRACK INJECTION TABLES

DRAWN BY : J. W. ARMFIELD / S. T. SANDOR DATE : 02/2017
 CHECKED BY : W. C. SMITH DATE : 02/2017

DOCUMENT NOT CONSIDERED FINAL UNLESS ALL SIGNATURES COMPLETED

REVISIONS						SHEET NO.
NO.	BY:	DATE:	NO.	BY:	DATE:	TOTAL SHEETS
1			3			14
2			4			37

RAIL REPAIR TABLE			
SPAN	RAIL	LOCATION	REPAIR SIZE
E	RIGHT RAIL	END OF POST	2.5 SQ FT
E	RIGHT RAIL	ON PARAPET WALL @ 17.0' FROM BENT 2	0.2 SQ FT

UNDERDECK & DIAPHRAGM REPAIR TABLE			
SPAN	BAY	LOCATION	REPAIR SIZE
B	2	MIDSPAN ON BOTTOM OF DECK	1.7 SQ FT
B	2	MID-SPAN ON SOUTH SIDE OF INTERMEDIATE DIAPHRAGM	2.2 SQ FT
B	2	15' FROM BENT 2 ON BOTTOM OF DECK	1.3 SQ FT
B	2	DIAPHRAGM AT BENT 2	1.0 SQ FT
C	2	DIAPHRAGM AT BENT 2	0.8 SQ FT
C	2	20' FROM BENT 3 ON BOTTOM OF DECK	2.5 SQ FT
C	2	10' FROM BENT 3 ON BOTTOM OF DECK	0.9 SQ FT
C	2	2' FROM BENT 3 ON BOTTOM OF DECK	0.6 SQ FT
D	2	MID-SPAN ON NORTH SIDE OF INTERMEDIATE DIAPHRAGM	2.2 SQ FT
D	2	20' FROM BENT 4 ON BOTTOM OF DECK	7.0 SQ FT
C	6	BOTTOM FLANGE @ 18" FROM BENT 3	0.2 SQ FT

GIRDER REPAIR TABLE			
SPAN	BAY	LOCATION	REPAIR SIZE
B	2	ON WEB AND BOTTOM FLANGE @ 4" FROM BENT 1	1.0 SQ FT
B	8	BOTTOM FLANGE @ END OF GIRDER	0.3 SQ FT
C	2	DIAPHRAGM AT BENT 2	0.8 SQ FT

REPAIR QUANTITY TABLE				
	QUANTITIES			
	ESTIMATE		ACTUAL	
SHOTCRETE REPAIRS	AREA SF	VOLUME CF	AREA SF	VOLUME CF
BOTTOM OF DECK	14.0	7.0		
GIRDER	7.7	3.4		
RAIL	2.7	1.4		
EPOXY RESIN INJECTION	LN. FT.		LN. FT.	
BOTTOM OF DECK	0.0			
GIRDER	0.0			

VALUES IN CHART REPRESENT ESTIMATED REPAIR TOTALS AFTER REMOVAL OF UNSOUND CONCRETE, MIN. OF 1" BEHIND REBAR AND MIN. 2" CL TO SAWCUT. SEE REPAIR DETAILS.

NOTES:

FOR CAP, COLUMN, AND RAIL REPAIR DETAILS, SEE "TYPICAL CAP, COLUMN, AND RAIL REPAIR DETAILS" SHEET.

FOR SHOTCRETE REPAIRS, SEE SPECIAL PROVISIONS.

FOR EPOXY RESIN INJECTION, SEE SPECIAL PROVISIONS.

FOR GIRDER REPAIR DETAILS, SEE "GIRDER REPAIR DETAILS" SHEET.

PROJECT NO. I-5977
HALIFAX COUNTY
 BRIDGE NO. 13

DocuSigned by:

 AD50B1D977494CC
 18565
 ENGINEER
 TIMOTHY M. SHEPPARD
 2/28/2017

STATE OF NORTH CAROLINA
 DEPARTMENT OF TRANSPORTATION
 RALEIGH
 SHOTCRETE REPAIR
 & CRACK INJECTION
 TABLES

DRAWN BY : J. W. ARMFIELD / S. T. SANDOR DATE : 02/2017
 CHECKED BY : W. C. SMITH DATE : 02/2017

DOCUMENT NOT CONSIDERED
 FINAL UNLESS ALL
 SIGNATURES COMPLETED

REVISIONS						SHEET NO.
NO.	BY:	DATE:	NO.	BY:	DATE:	TOTAL SHEETS
1			3			15
2			4			37

CONTRACTOR SHALL FIELD VERIFY THE EXISTING FORMED OPENING PRIOR TO OBTAINING JOINT MATERIAL.

FOR REPLACEMENT OF FOAM JOINT SEALS, SEE SPECIAL PROVISIONS.

THE WIDTH OF THE UNCOMPRESSED FOAM JOINT MATERIAL SHALL BE 2 1/2"

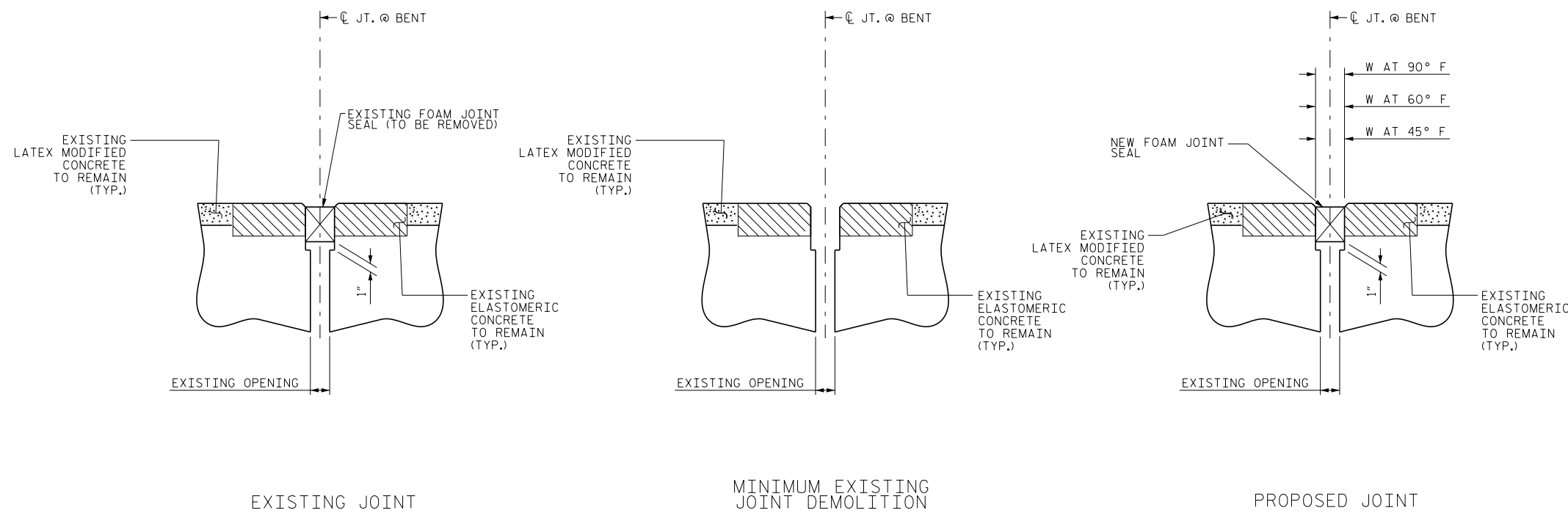

FOAM JOINT REPLACEMENT SEQUENCE AT BENTS

SAWED OPENING FOR FOAM JOINT

BENT NO.	W AT 90° F	W AT 60° F	W AT 45° F
BENT 1	1 7/8"	2"	2 1/16"
BENT 2	1 7/8"	2"	2 1/16"
BENT 3	1 7/8"	2"	2 1/16"
BENT 4	1 3/4"	2"	2 1/8"

PROJECT NO. I-5977
HALIFAX COUNTY
 BRIDGE NO. 12 & 13

DocuSigned by:
Timothy M. Sherrill
 AD50B1D9774CC...
 PROFESSIONAL SEAL
 18565
 ENGINEER
 TIMOTHY M. SHERRILL
 2/28/2017

STATE OF NORTH CAROLINA
 DEPARTMENT OF TRANSPORTATION
 RALEIGH
 JOINT DETAILS

DRAWN BY : S. T. SANDOR DATE : 02/2017
 CHECKED BY : W. C. SMITH DATE : 02/2017

DOCUMENT NOT CONSIDERED FINAL UNLESS ALL SIGNATURES COMPLETED

REVISIONS						SHEET NO.
NO.	BY:	DATE:	NO.	BY:	DATE:	TOTAL SHEETS
1			3			37
2			4			

SCOPE OF WORK

- BRIDGE DECK PREPARATION.
- EPOXY OVERLAY.
- JOINT DEMOLITION AND REPLACEMENT.

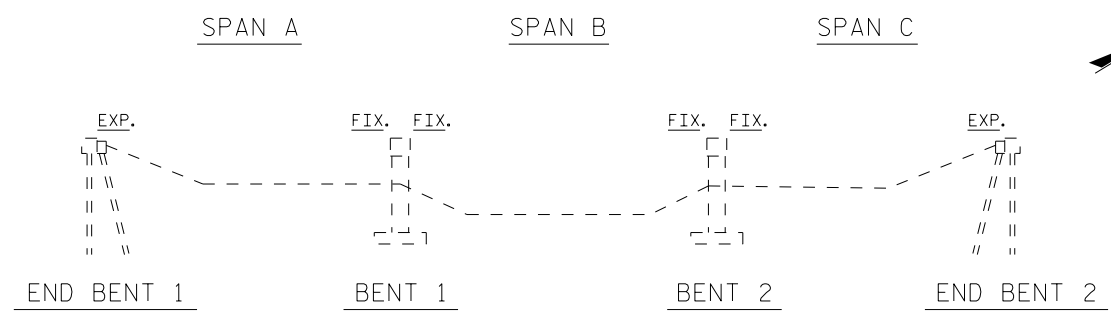

ELEVATION

SECTIONS AT BENTS AND END BENTS ARE AT RIGHT ANGLES

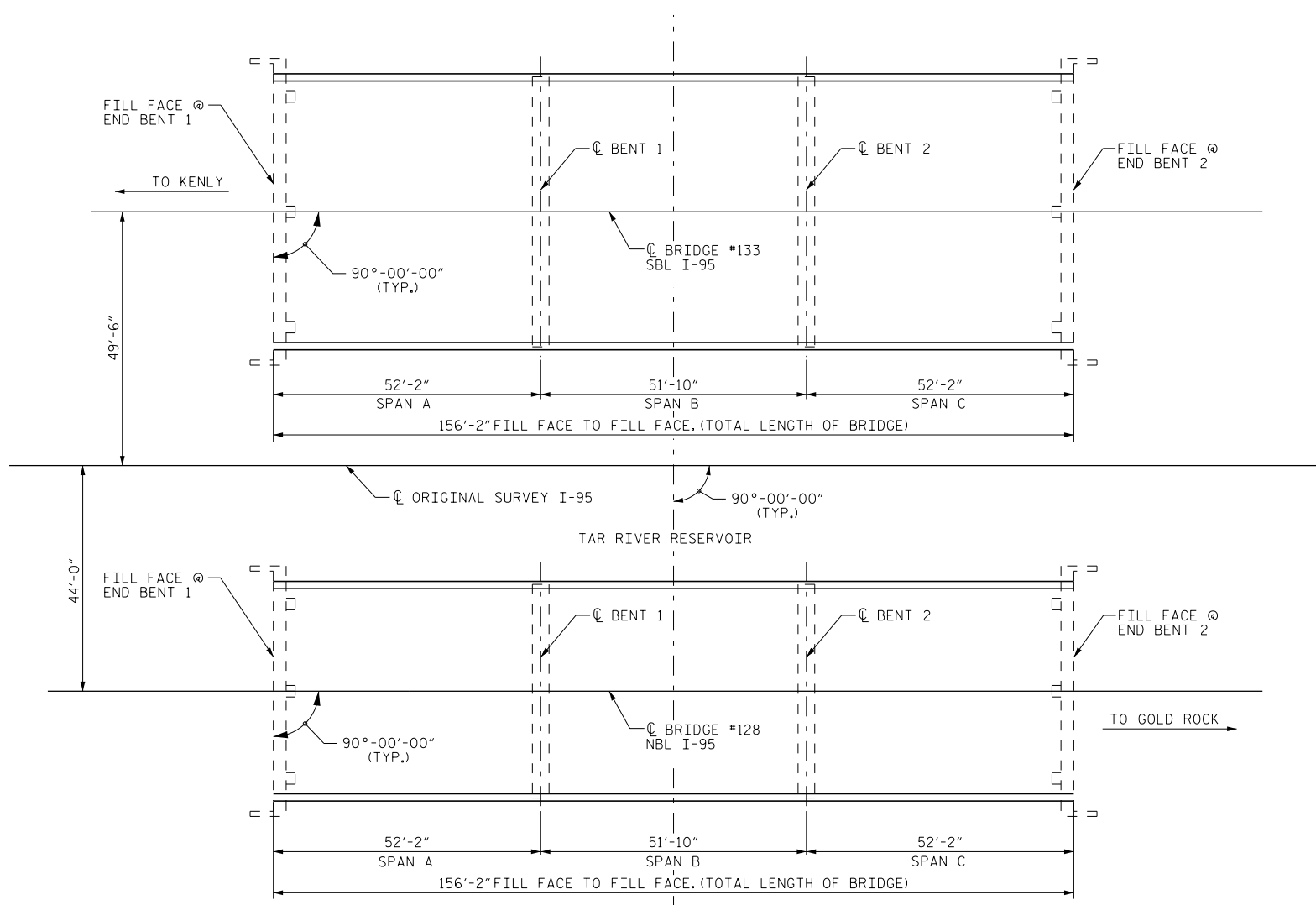

PLAN

COLUMNS AND FOOTINGS NOT SHOWN IN PLAN VIEW FOR CLARITY

PROJECT NO. I-5977
 NASH COUNTY
 BRIDGE NO.: 128 & 133

DocuSigned by:
Timothy M. Sheppard
 AD50B3D971494CC...
 PROFESSIONAL SEAL
 18565
 ENGINEER
 TIMOTHY M. SHEPPARD

STATE OF NORTH CAROLINA
 DEPARTMENT OF TRANSPORTATION
 RALEIGH
 GENERAL DRAWING
 BRIDGES OVER SAPONY CREEK
 ON I-95 NBL & SBL
 BETWEEN
 KENLY & GOLD ROCK

2/28/2017

DRAWN BY : D. V. JOYNER DATE : 10/2016
 CHECKED BY : W. C. SMITH DATE : 10/2016

REVISIONS						SHEET NO.
NO.	BY:	DATE:	NO.	BY:	DATE:	TOTAL SHEETS
1			3			S-17
DOCUMENT NOT CONSIDERED FINAL UNLESS ALL SIGNATURES COMPLETED						37

NOTE:
SEE TRAFFIC MANAGEMENT PLANS FOR LANE WIDTHS, SEQUENCING, AND OTHER TRAFFIC CONTROL MEASURES FOR STAGING OF EPOXY OVERLAY SYSTEM AND SURFACE PREPARATION.

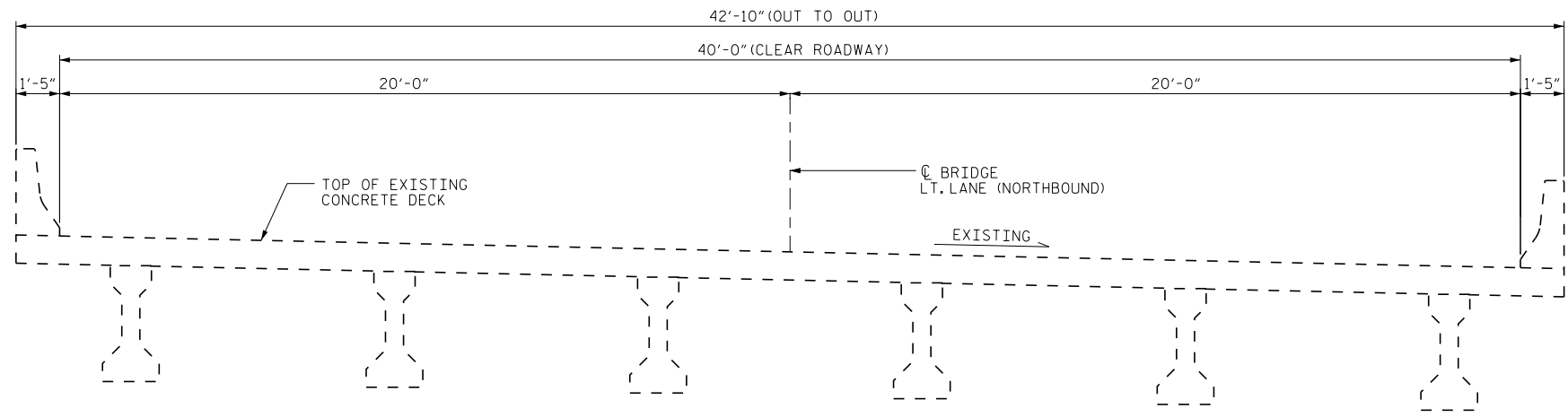

TYPICAL SECTION
(EXISTING)

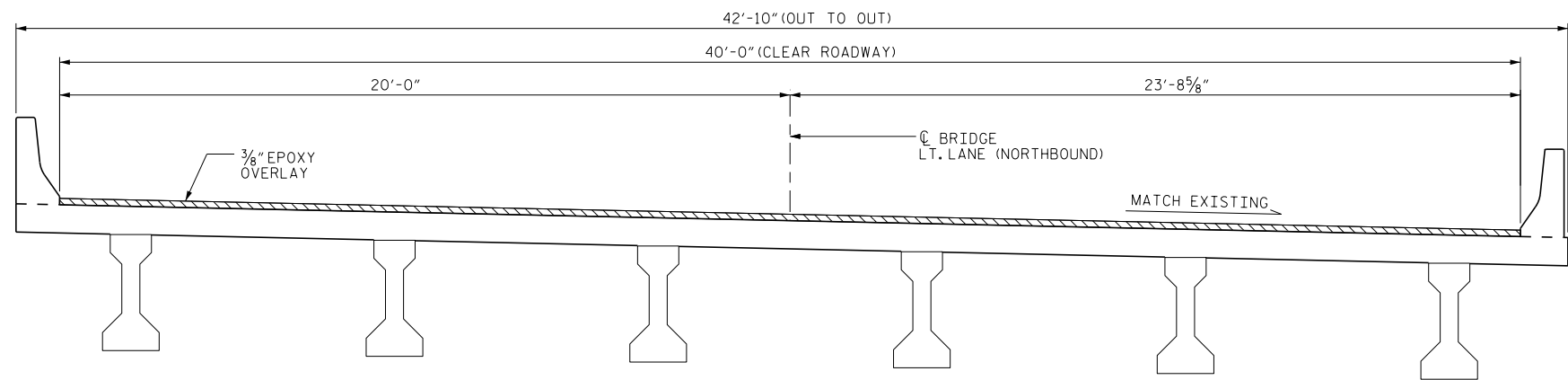

TYPICAL SECTION
(PROPOSED)

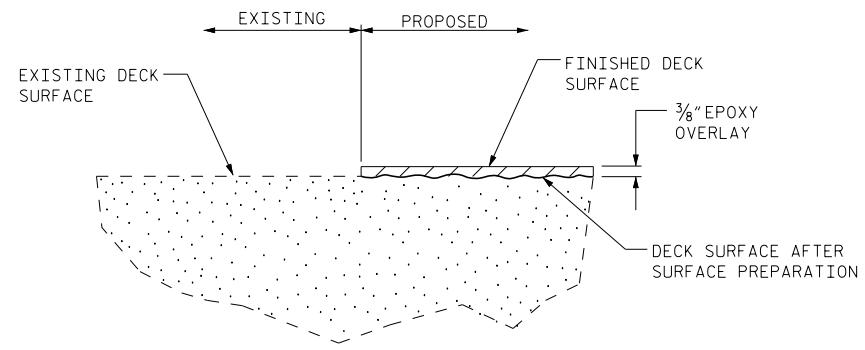

DETAIL OF EPOXY OVERLAY

PROJECT NO. I-5977
NASH COUNTY
BRIDGE NO. 128

DocuSigned by:
Timothy M. Sherill
AD50B1D9774
PROFESSIONAL ENGINEER
SEAL
18565
TIMOTHY M. SHERILL
2/28/2017

STATE OF NORTH CAROLINA
DEPARTMENT OF TRANSPORTATION
RALEIGH
SUPERSTRUCTURE
TYPICAL SECTION
& EPOXY OVERLAY
DETAILS

DRAWN BY : D.V. JOYNER DATE : 10/2016
CHECKED BY : W. SMITH DATE : 2/2017

REVISIONS						SHEET NO.
NO.	BY:	DATE:	NO.	BY:	DATE:	S-18
1			3			TOTAL SHEETS
2			4			37

DOCUMENT NOT CONSIDERED FINAL UNLESS ALL SIGNATURES COMPLETED

SUMMARY OF QUANTITIES		
	ESTIMATE	ACTUAL
BRIDGE JOINT DEMOLITION	64.0 SQ. FT.	
CONCRETE DECK REPAIR FOR EPOXY OVERLAY	* 30 SQ. FT.	
EPOXY OVERLAY SYSTEM	7143 SQ. FT.	

NOTE:
 * CONCRETE DECK REPAIR FOR EPOXY OVERLAY IS NOT ANTICIPATED. TOKEN PAY ITEMS ARE INDICATED FOR PRICING PURPOSE IN CASE UNANTICIPATED REPAIR AREAS ARE ENCOUNTERED.

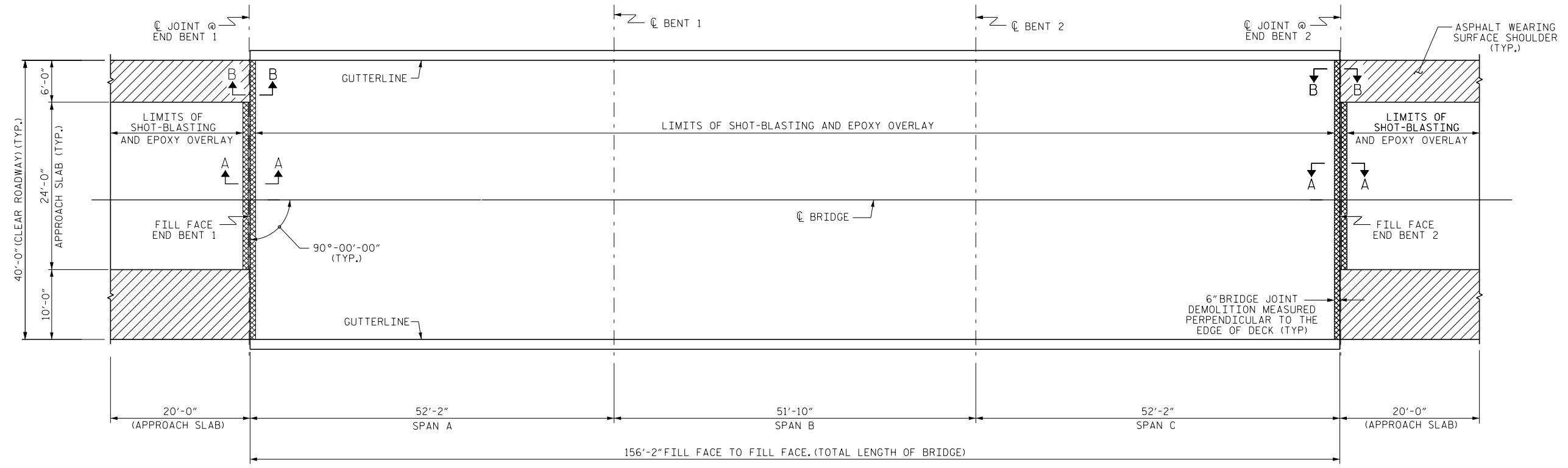

PLAN
 (FOR SECTION A-A & B-B, SEE JOINT DETAIL SHEET S-21)

- EPOXY OVERLAY
- BRIDGE JOINT DEMOLITION
- ASPHALT SHOULDER

PROJECT NO. I-5977
NASH COUNTY
 BRIDGE NO. 128

DocuSigned by:

 AD50B ED977 494CC
 PROFESSIONAL ENGINEER
 SEAL
 18565
 TIMOTHY M. SHERRILL
 2/28/2017

STATE OF NORTH CAROLINA
 DEPARTMENT OF TRANSPORTATION
 RALEIGH
SUPERSTRUCTURE
 SURFACE PREPARATION
 & EPOXY OVERLAY

DRAWN BY : B. N. BARODAWALA / S. T. SANDOR DATE : 02/2017
 CHECKED BY : W. C. SMITH DATE : 02/2017

REVISIONS						SHEET NO.
NO.	BY:	DATE:	NO.	BY:	DATE:	TOTAL SHEETS
1			3			37
2			4			

DOCUMENT NOT CONSIDERED FINAL UNLESS ALL SIGNATURES COMPLETED

NOTE:
 SEE TRAFFIC MANAGEMENT PLANS FOR LANE WIDTHS,
 SEQUENCING, AND OTHER TRAFFIC CONTROL
 MEASURES FOR STAGING OF EPOXY OVERLAY SYSTEM
 AND SURFACE PREPARATION.

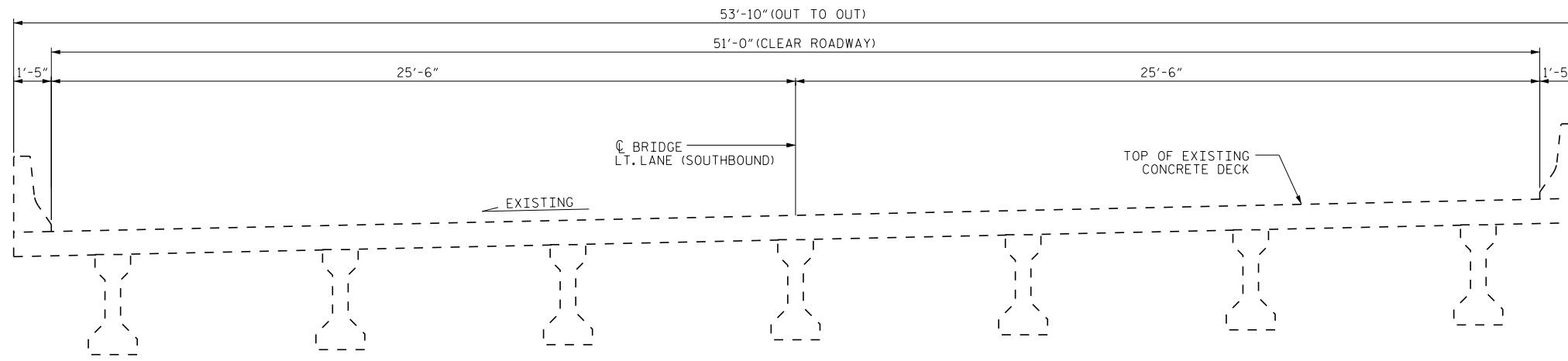

TYPICAL SECTION
(EXISTING)

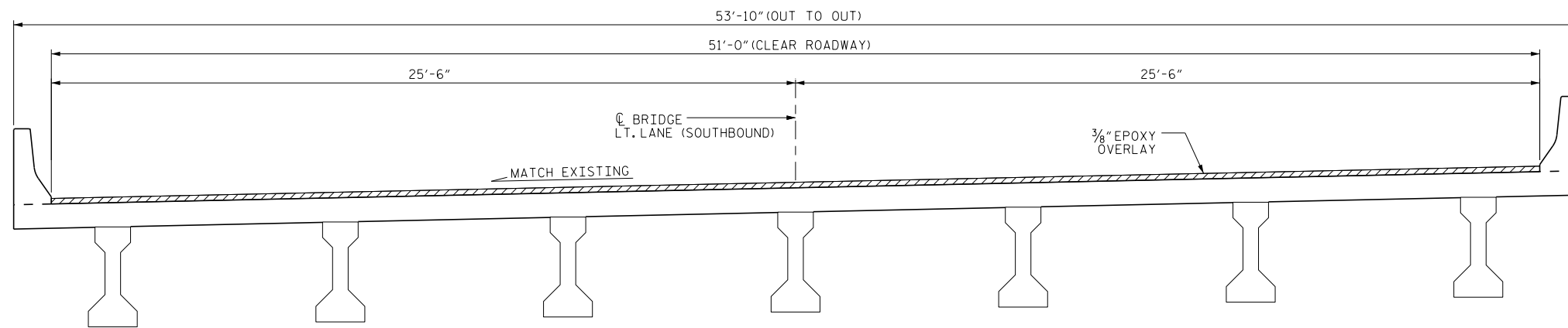

TYPICAL SECTION
(PROPOSED)

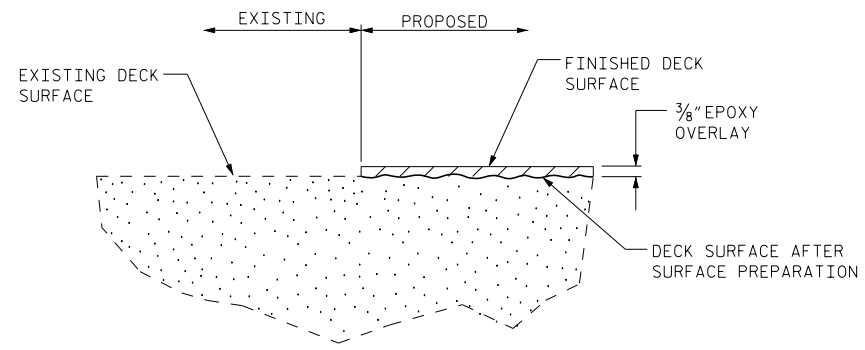

DETAIL OF EPOXY OVERLAY

PROJECT NO. I-5977
NASH COUNTY
 BRIDGE NO. 133

DocuSigned by:
Timothy M. Shearill
 AD50B1597769
 PROFESSIONAL SEAL
 18565
 ENGINEER
 TIMOTHY M. SHEARILL

2/28/2017

STATE OF NORTH CAROLINA
 DEPARTMENT OF TRANSPORTATION
 RALEIGH
 SUPERSTRUCTURE
 TYPICAL SECTION
 & EPOXY OVERLAY
 DETAILS

DRAWN BY : D.V. JOYNER DATE : 10/2016
 CHECKED BY : W. SMITH DATE : 2/2017

DOCUMENT NOT CONSIDERED
 FINAL UNLESS ALL
 SIGNATURES COMPLETED

REVISIONS						SHEET NO.
NO.	BY:	DATE:	NO.	BY:	DATE:	TOTAL SHEETS
1			3			5-20
2			4			37

SUMMARY OF QUANTITIES		
	ESTIMATE	ACTUAL
BRIDGE JOINT DEMOLITION	88.5 SQ. FT.	
CONCRETE DECK REPAIR FOR EPOXY OVERLAY	* 40 SQ. FT.	
EPOXY OVERLAY SYSTEM	9,376 SQ. FT.	

NOTE:
 * CONCRETE DECK REPAIR FOR EPOXY OVERLAY IS NOT ANTICIPATED. TOKEN PAY ITEMS ARE INDICATED FOR PRICING PURPOSE IN CASE UNANTICIPATED REPAIR AREAS ARE ENCOUNTERED.

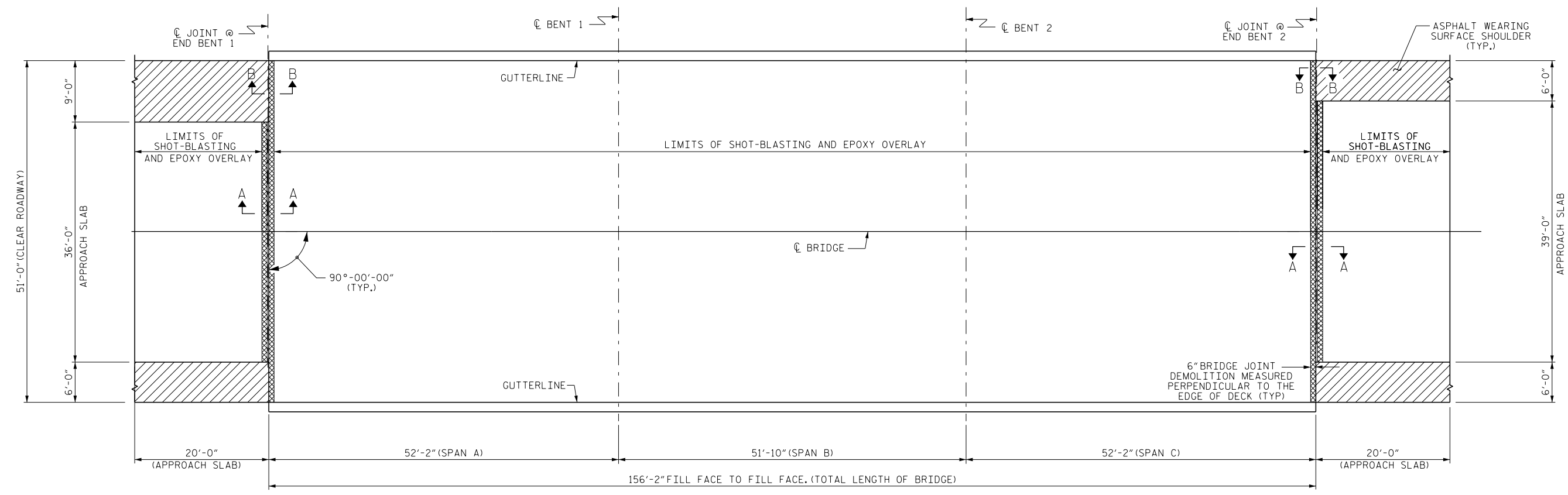

PLAN
 (FOR SECTION A-A & B-B, SEE JOINT DETAIL SHEET S-21)

- EPOXY OVERLAY
- BRIDGE JOINT DEMOLITION
- ASPHALT SHOULDER

PROJECT NO. I-5977
NASH COUNTY
 BRIDGE NO. 133

DocuSigned by:

 AD50B ED977 894CC
 PROFESSIONAL SEAL
 18565
 ENGINEER
 TIMOTHY M. SHERRILL
 2/28/2017

STATE OF NORTH CAROLINA
 DEPARTMENT OF TRANSPORTATION
 RALEIGH
SUPERSTRUCTURE
 SURFACE PREPARATION
 & EPOXY OVERLAY

DRAWN BY : B.N.BARODAWALA / S.T. SANDOR DATE : 02/2017
 CHECKED BY : W.C.SMITH DATE : 02/2017

REVISIONS						SHEET NO.
NO.	BY:	DATE:	NO.	BY:	DATE:	
1			3			S-21
2			4			TOTAL SHEETS 37

NOTES:
 CONTRACTOR SHALL FIELD VERIFY THE EXISTING FORMED OPENING PRIOR TO OBTAINING JOINT MATERIAL.
 FOR SILICONE JOINT SEALANT, SEE SPECIAL PROVISIONS.
 FOR ELASTOMERIC CONCRETE, SEE SPECIAL PROVISIONS.
 RETAIN ALL EXISTING REINFORCING STEEL. CLEAN AND REPAIR AS NEEDED.

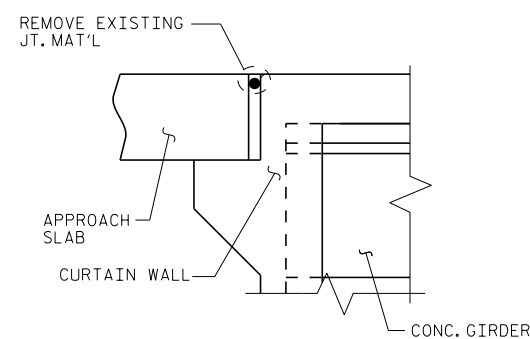

EXISTING

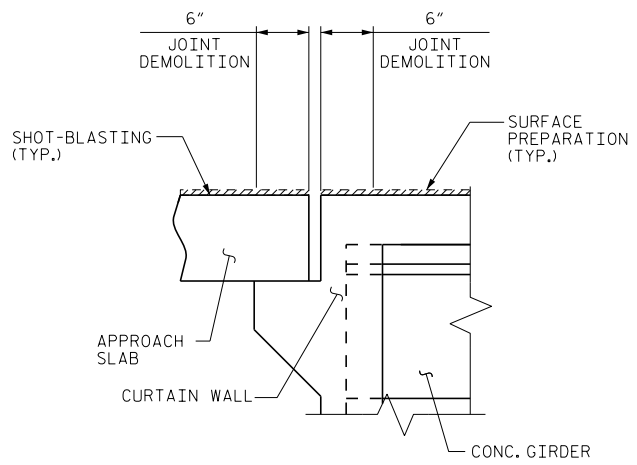

MINIMUM EXISTING JOINT DEMOLITION

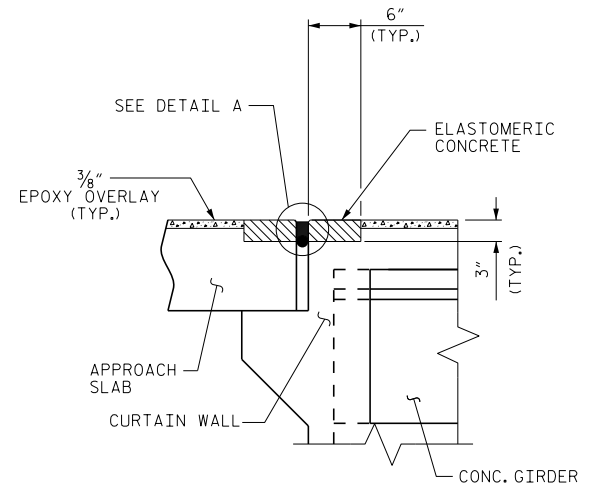

PROPOSED JOINT

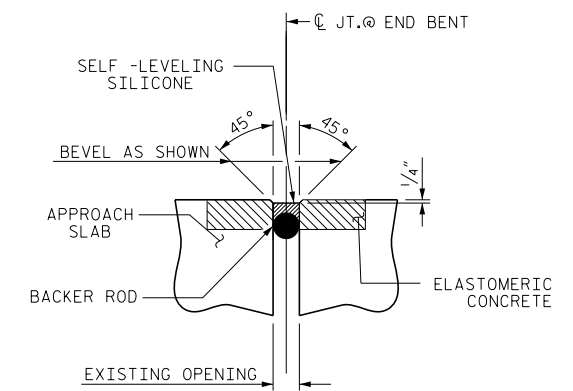

DETAIL A (PROPOSED)

JOINT INSTALLATION SEQUENCE AT END BENTS
 SECTION A-A

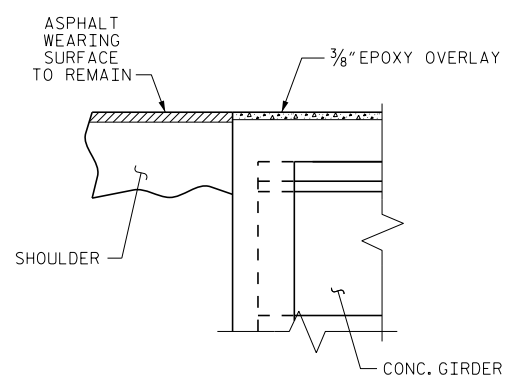

SECTION B-B (PROPOSED)

PROJECT NO. I-5977
NASH COUNTY
 BRIDGE NO. 128 & 133

DocuSigned by:
 Timothy M. Sherrill
 AD50B3D977494CC
 PROFESSIONAL SEAL
 18565
 ENGINEER
 TIMOTHY M. SHERRILL

2/28/2017

STATE OF NORTH CAROLINA
 DEPARTMENT OF TRANSPORTATION
 RALEIGH

JOINT DETAILS

REVISIONS						SHEET NO.
NO.	BY:	DATE:	NO.	BY:	DATE:	
1			3			S-22
2			4			TOTAL SHEETS 37

DRAWN BY : B. N. BARODAWALA / S. T. SANDOR DATE : 02/2017
 CHECKED BY : W. C. SMITH DATE : 02/2017

DOCUMENT NOT CONSIDERED FINAL UNLESS ALL SIGNATURES COMPLETED

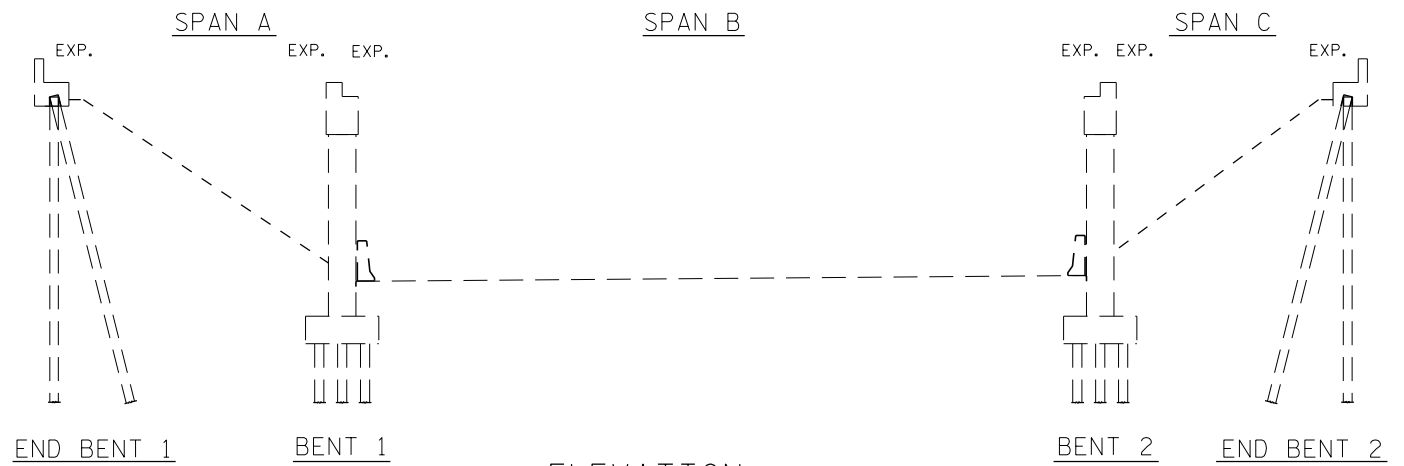

- SCOPE OF WORK**
- BRIDGE DECK PREPARATION.
 - EPOXY OVERLAY.
 - JOINT DEMOLITION AND REPLACEMENT.
 - SHOTCRETE REPAIRS AND EPOXY RESIN INJECTION OF GIRDERS, SUBSTRUCTURE, UNDERDECK, AND RAIL.
 - CLEANING AND EPOXY COATING SUBSTRUCTURE CAPS.
 - GIRDER REPAIRS.

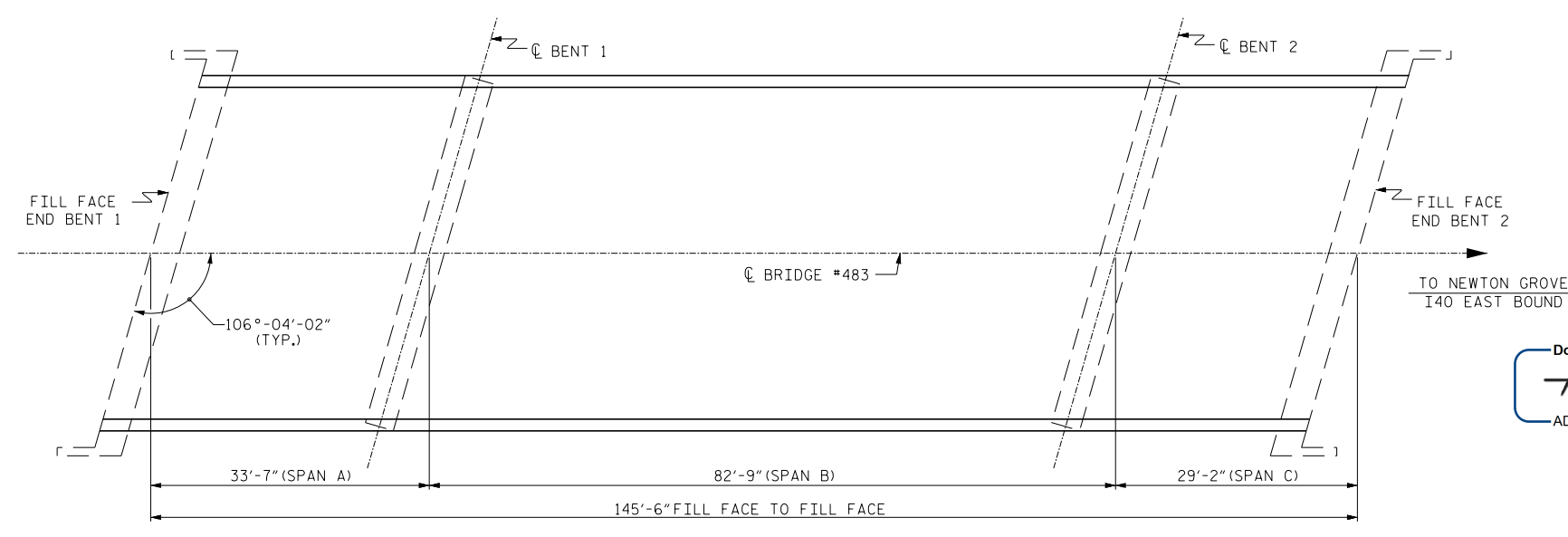
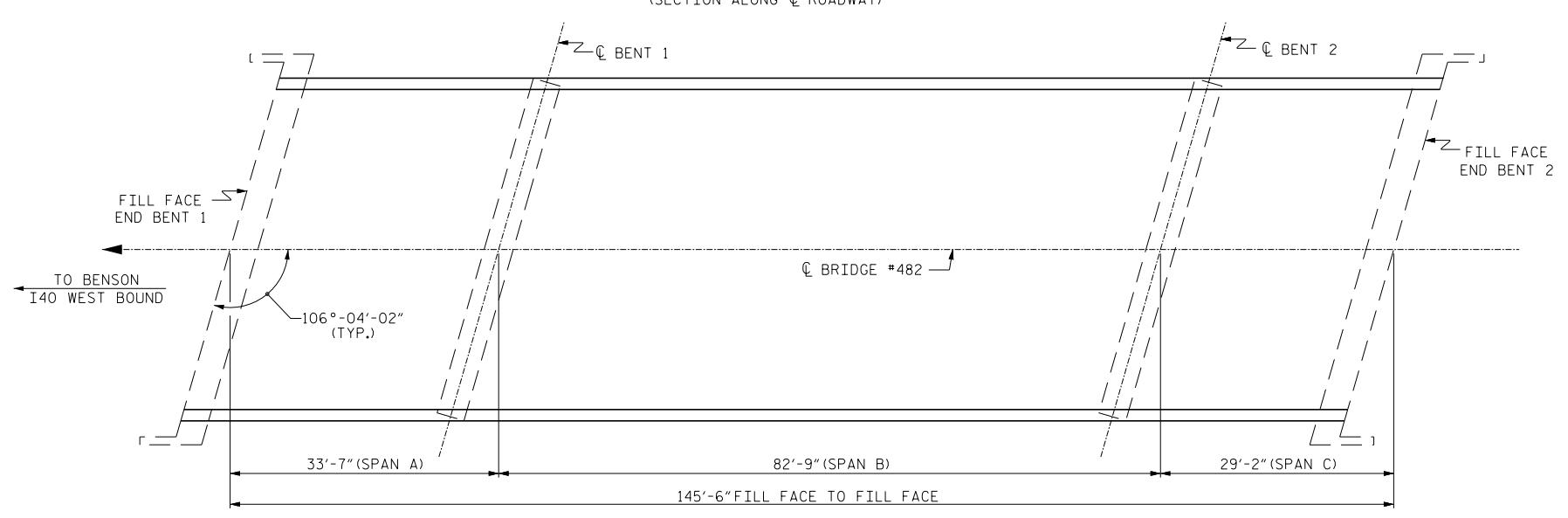

PROJECT NO. I-5977
JOHNSTON COUNTY
 BRIDGE NO. 482 & 483

DocuSigned by:
Timothy M. Skerrill
 AD50B18974894CC-18565
 PROFESSIONAL ENGINEER
 TIMOTHY M. SKERRILL

2/28/2017

STATE OF NORTH CAROLINA
 DEPARTMENT OF TRANSPORTATION
 RALEIGH

GENERAL DRAWING
 BRIDGES OVER NC 96
 ON I-40 BETWEEN
 SR 1005 & SR 1124

DRAWN BY : M. WELDON / S. T. SANDOR DATE : 02/2017
 CHECKED BY : W. C. SMITH DATE : 02/2017

REVISIONS						SHEET NO.
NO.	BY:	DATE:	NO.	BY:	DATE:	TOTAL SHEETS
1			3			5-23
2			4			37

DOCUMENT NOT CONSIDERED FINAL UNLESS ALL SIGNATURES COMPLETED

NOTE:
SEE TRAFFIC MANAGEMENT PLANS FOR LANE WIDTHS, SEQUENCING, AND OTHER TRAFFIC CONTROL MEASURES FOR STAGING OF EPOXY OVERLAY SYSTEM AND SURFACE PREPARATION.

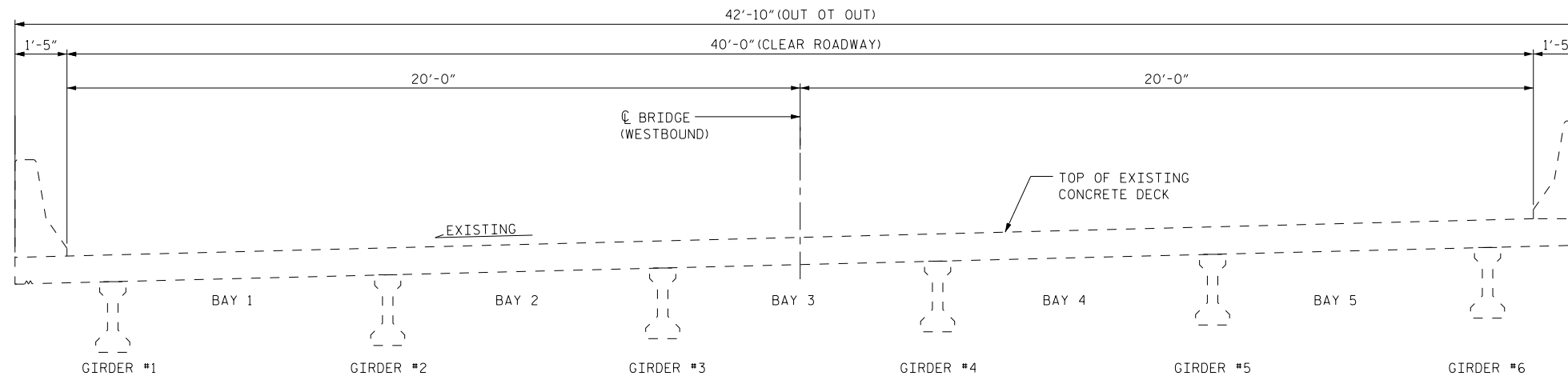

TYPICAL SECTION
(EXISTING BRIDGE #482 I-40 WBL)
(EXISTING BRIDGE #483 I-40 EBL SIMILAR BY ROTATION)

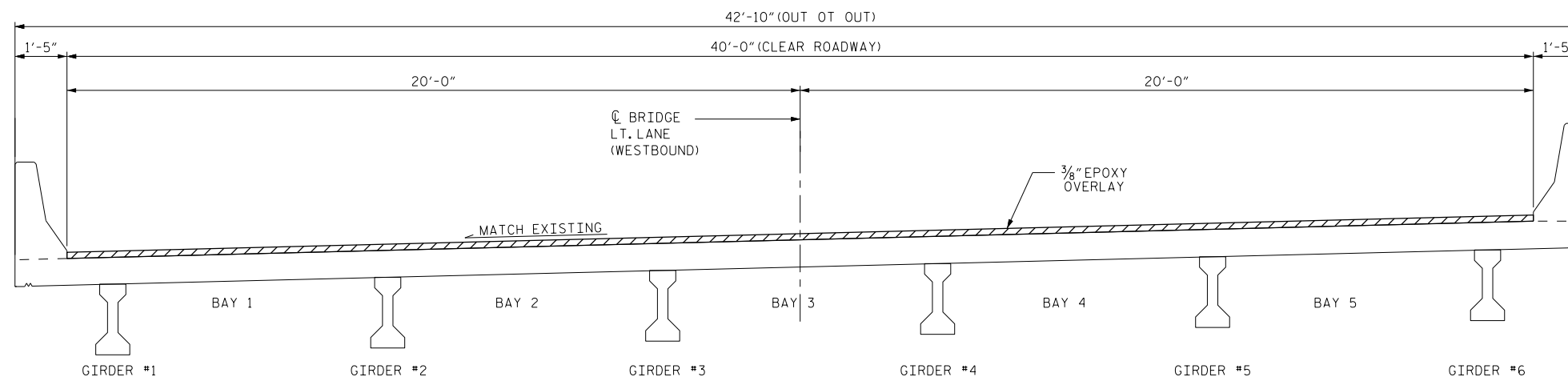

TYPICAL SECTION
(PROPOSED BRIDGE #482 I-40 WBL)
(PROPOSED BRIDGE #483 I-40 EBL SIMILAR BY ROTATION)

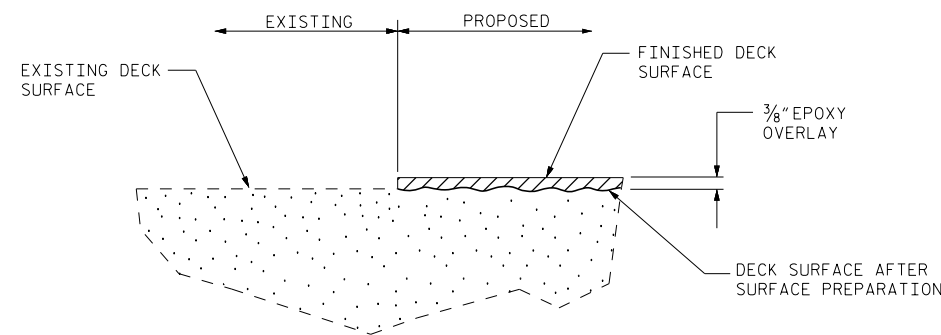

DETAIL OF EPOXY OVERLAY

PROJECT NO. I-5977
JOHNSTON COUNTY
BRIDGE NO. 482 & 483

DocuSigned by:
Timothy M. Shephard
AD50B3D97484CC...
SEAL
18565
ENGINEER
TIMOTHY M. SHEPHERD

2/28/2017

STATE OF NORTH CAROLINA
DEPARTMENT OF TRANSPORTATION
RALEIGH
SUPERSTRUCTURE
TYPICAL SECTIONS &
EPOXY OVERLAY DETAILS

DRAWN BY : M. WELDON / S. T. SANDOR DATE : 10/2016
CHECKED BY : W. C. SMITH DATE : 10/2016

DOCUMENT NOT CONSIDERED
FINAL UNLESS ALL
SIGNATURES COMPLETED

REVISIONS						SHEET NO.
NO.	BY:	DATE:	NO.	BY:	DATE:	S-24
1			3			TOTAL SHEETS
2			4			37

SUMMARY OF QUANTITIES

	ESTIMATE	ACTUAL
CONCRETE DECK REPAIR FOR EPOXY OVERLAY	*30 SQ. FT.	
EPOXY OVERLAY SYSTEM	6,614 SQ. FT.	
BRIDGE JOINT DEMOLITION	166.5 SQ. FT.	

NOTE:
 * CONCRETE DECK REPAIR FOR EPOXY OVERLAY IS NOT ANTICIPATED, TOKEN PAY ITEMS ARE INDICATED FOR PRICING PURPOSE IN CASE UNANTICIPATED REPAIR AREAS ARE ENCOUNTERED.

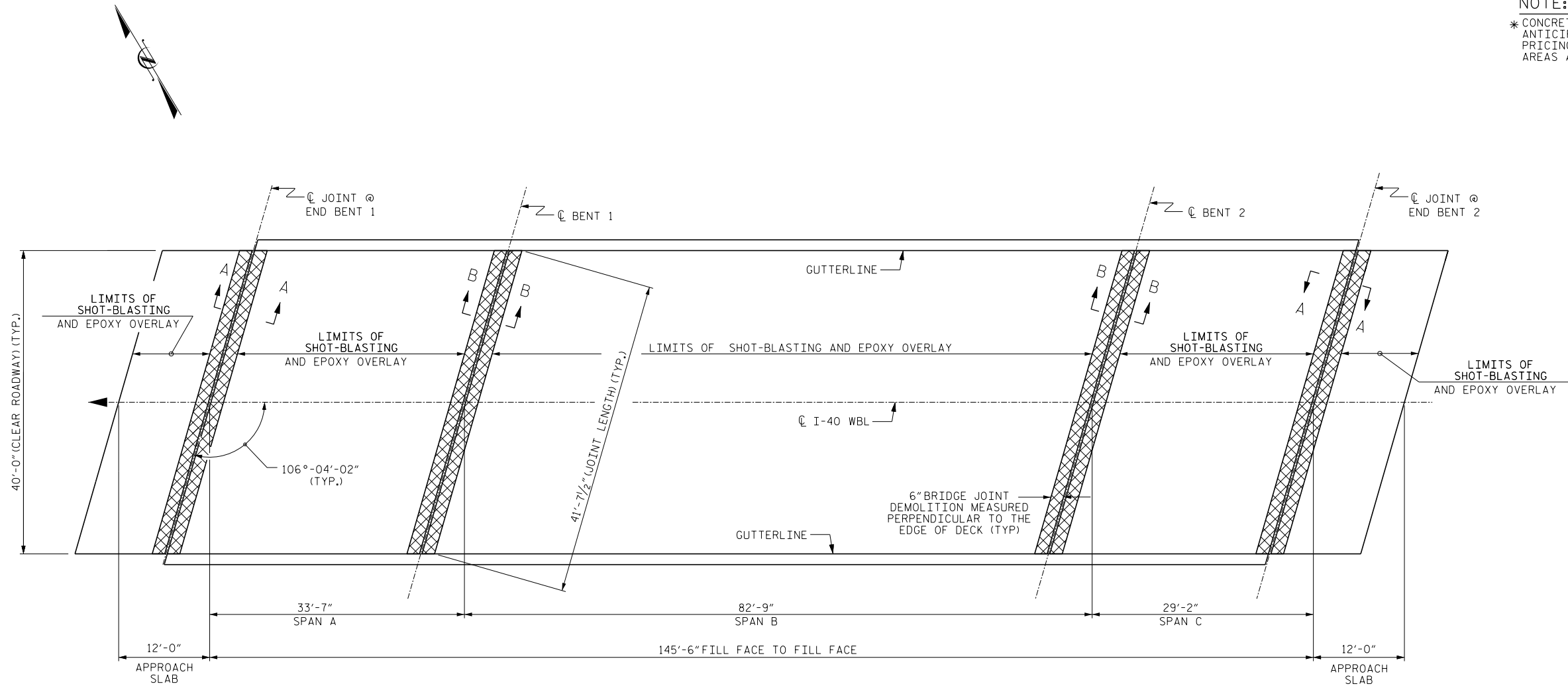
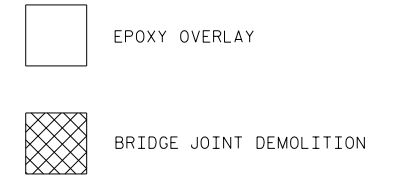

PROJECT NO. I-5977
 JOHNSTON COUNTY
 BRIDGE NO. 482

DocuSigned by:
 Timothy M. Sherrill
 AD50B1B97749CC
 PROFESSIONAL SEAL
 18565
 ENGINEER
 TIMOTHY M. SHERRILL
 2/28/2017

STATE OF NORTH CAROLINA
 DEPARTMENT OF TRANSPORTATION
 RALEIGH
 SUPERSTRUCTURE
 SURFACE PREPARATION
 & EPOXY OVERLAY

DRAWN BY : S. T. SANDOR DATE : 02/2017
 CHECKED BY : W. C. SMITH DATE : 02/2017

REVISIONS						SHEET NO.
NO.	BY:	DATE:	NO.	BY:	DATE:	TOTAL SHEETS
1			3			37
2			4			

DOCUMENT NOT CONSIDERED FINAL UNLESS ALL SIGNATURES COMPLETED

REPAIR QUANTITY TABLE

REPAIRS END BENT 1	QUANTITIES			
	ESTIMATE		ACTUAL	
SHOTCRETE REPAIRS	AREA SF	VOLUME CF	AREA SF	VOLUME CF
CAP (VERTICAL FACE)	0.0	0.0		
CAP (HORIZONTAL, CORNER)	0.0	0.0		
EPOXY RESIN INJECTION		LN. FT.	LN. FT.	
CAP		29.0		
EPOXY COATING		AREA SF		
TOP OF CAP		119.0		

REPAIRS END BENT 2	QUANTITIES			
	ESTIMATE		ACTUAL	
SHOTCRETE REPAIRS	AREA SF	VOLUME CF	AREA SF	VOLUME CF
CAP (VERTICAL FACE)	0.0	0.0		
CAP (HORIZONTAL, CORNER)	0.0	0.0		
EPOXY RESIN INJECTION		LN. FT.	LN. FT.	
CAP		77.0		
EPOXY COATING		AREA SF		
TOP OF CAP		119.0		

NOTES:

REPAIR LOCATIONS AND ESTIMATE OF QUANTITIES ARE GIVEN WITH THE BEST INFORMATION AVAILABLE. IF ADDITIONAL REPAIRS NOT SHOWN ON THE DRAWINGS ARE DEEMED NECESSARY BY THE INSPECTOR OR ENGINEER THE CONTRACTOR SHALL NOTE ON THE DRAWINGS THE APPROXIMATE LOCATION AND DESCRIPTION OF THE REPAIRS AND ADJUST THE ACTUAL QUANTITIES ENTERED INTO THE REPAIR QUANTITY TABLE.

FOR CAP AND COLUMN REPAIR DETAILS, SEE "TYPICAL CAP, COLUMN, AND RAIL REPAIR DETAILS" SHEET.

FOR SHOTCRETE REPAIRS, SEE SPECIAL PROVISIONS.

FOR EPOXY RESIN INJECTION, SEE SPECIAL PROVISIONS.

VALUES IN CHART REPRESENT ESTIMATED REPAIR TOTALS AFTER REMOVAL OF UNSOUND CONCRETE, MIN. OF 1" BEHIND REBAR AND MIN. 2" CL TO SAWCUT. SEE REPAIR DETAILS.



ERI - EPOXY RESIN INJECTION

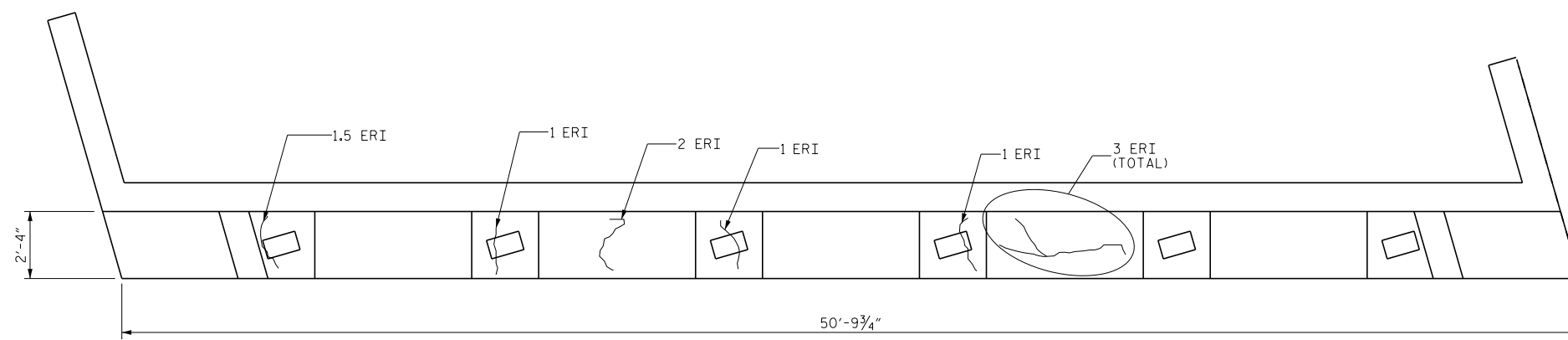

PLAN
END BENT 1

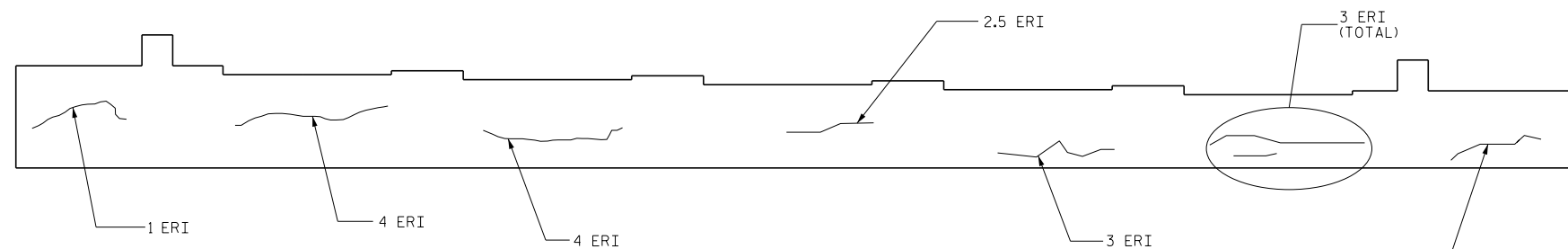

ELEVATION
END BENT 1

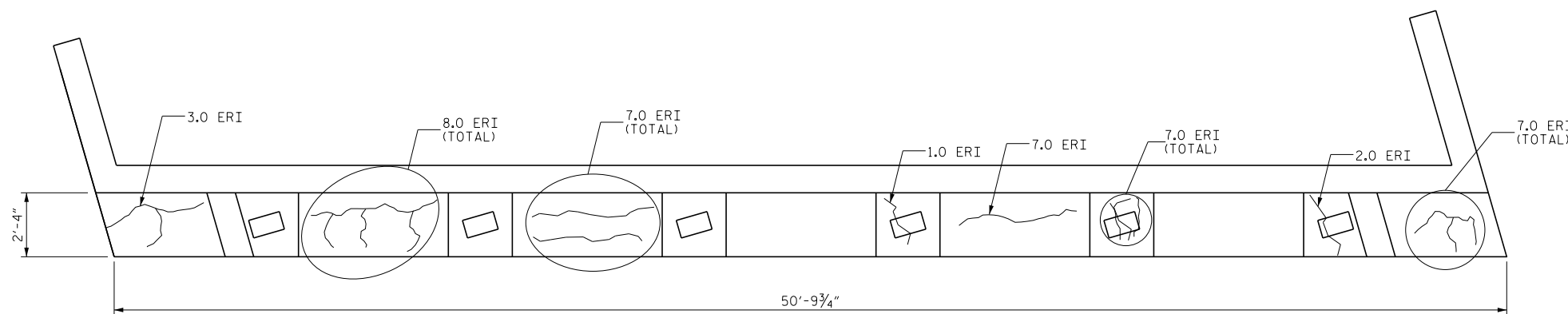

PLAN
END BENT 2

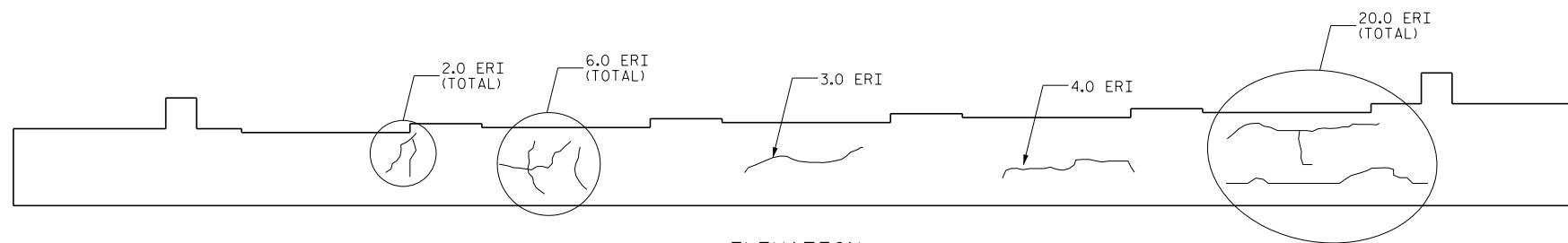

ELEVATION
END BENT 2

PROJECT NO. I-5977
JOHNSTON COUNTY
 BRIDGE NO. 482

DocuSigned by:

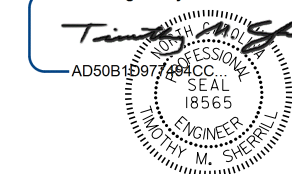

2/28/2017

STATE OF NORTH CAROLINA
 DEPARTMENT OF TRANSPORTATION
 RALEIGH

SUBSTRUCTURE
END BENTS

DRAWN BY : J. W. ARMFIELD / S. T. SANDOR DATE : 02/2017
 CHECKED BY : W. C. SMITH DATE : 02/2017

DOCUMENT NOT CONSIDERED
 FINAL UNLESS ALL
 SIGNATURES COMPLETED

REVISIONS						SHEET NO.
NO.	BY:	DATE:	NO.	BY:	DATE:	TOTAL SHEETS
1			3			37
2			4			

NO REPAIRS NOTED DURING INSPECTION BY STRUCTURES MANAGEMENT UNIT. THE CONTRACTOR AND ENGINEER SHALL INSPECT THE BENT PRIOR TO BEGINNING WORK.

NOTES:

REPAIR LOCATIONS AND ESTIMATE OF QUANTITIES ARE GIVEN WITH THE BEST INFORMATION AVAILABLE. IF ADDITIONAL REPAIRS NOT SHOWN ON THE DRAWINGS ARE DEEMED NECESSARY BY THE INSPECTOR OR ENGINEER THE CONTRACTOR SHALL NOTE ON THE DRAWINGS THE APPROXIMATE LOCATION AND DESCRIPTION OF THE REPAIRS AND ADJUST THE ACTUAL QUANTITIES ENTERED INTO THE REPAIR QUANTITY TABLE.

FOR CAP AND COLUMN REPAIR DETAILS, SEE "TYPICAL CAP, COLUMN, AND RAIL REPAIR DETAILS" SHEET.

FOR SHOTCRETE REPAIRS, SEE SPECIAL PROVISIONS.

FOR EPOXY RESIN INJECTION, SEE SPECIAL PROVISIONS.

REPAIR QUANTITY TABLE

REPAIRS BENT 1	QUANTITIES			
	ESTIMATE		ACTUAL	
SHOTCRETE REPAIRS	AREA SF	VOLUME CF	AREA SF	VOLUME CF
CAP (VERTICAL FACE)	0.0	0.0		
CAP (HORIZONTAL, CORNER)	0.0	0.0		
COLUMN	0.0	0.0		
EPOXY RESIN INJECTION		LN. FT.		LN. FT.
CAP		0.0		
COLUMN		0.0		
EPOXY COATING	AREA SF			
TOP OF CAP	153.0			

VALUES IN CHART REPRESENT ESTIMATED REPAIR TOTALS AFTER REMOVAL OF UNSOUND CONCRETE, MIN. OF 1" BEHIND REBAR AND MIN. 2" CL TO SAWCUT. SEE REPAIR DETAILS.

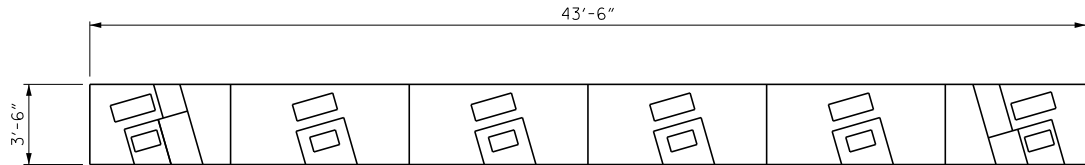

PLAN
TOP OF CAP

SPAN B
SPAN A

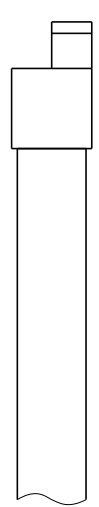

END VIEW
NORTH SIDE

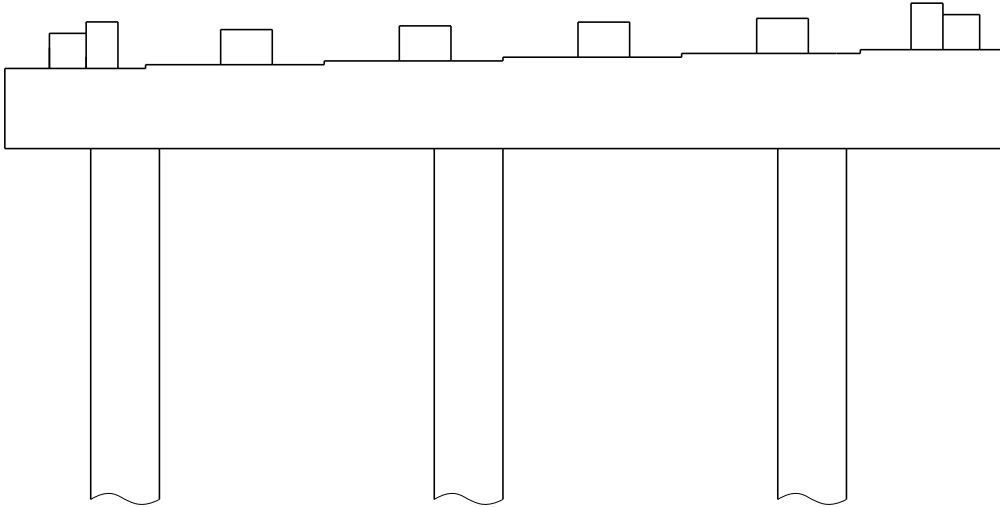

ELEVATION
WEST SIDE



END VIEW
SOUTH SIDE

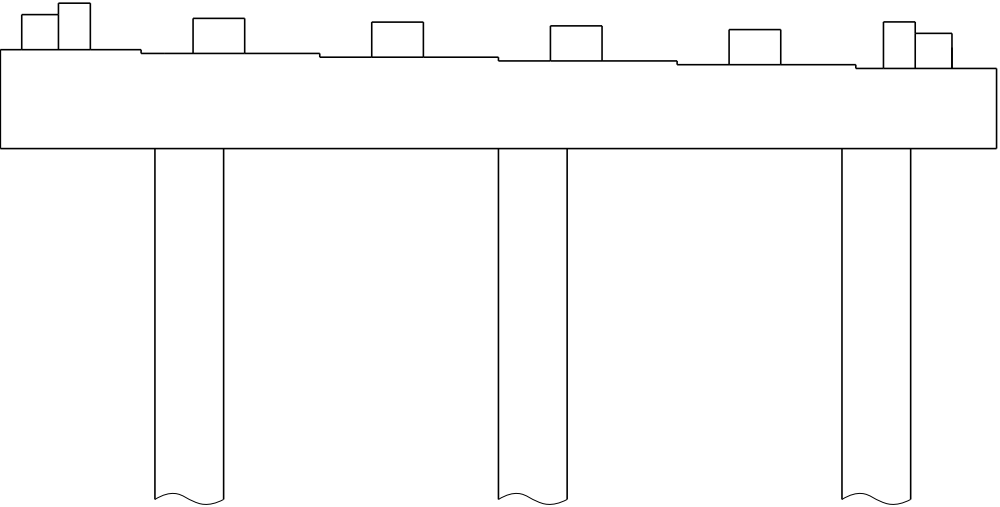

ELEVATION
EAST SIDE

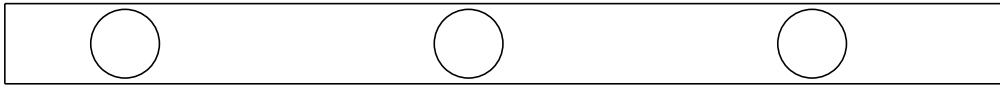

PLAN
BOTTOM OF CAP

PROJECT NO. I-5977
JOHNSTON COUNTY
BRIDGE NO. 482

DocuSigned by:
Timothy M. Sherrill
AD50B5D971484CC
PROFESSIONAL
SEAL
18565
ENGINEER
TIMOTHY M. SHERRILL
2/28/2017

STATE OF NORTH CAROLINA
DEPARTMENT OF TRANSPORTATION
RALEIGH
SUBSTRUCTURE
BENT 1

DRAWN BY : J. W. ARMFIELD / S. T. SANDOR DATE : 02/2017
CHECKED BY : W. C. SMITH DATE : 02/2017

REVISIONS						SHEET NO.
NO.	BY:	DATE:	NO.	BY:	DATE:	TOTAL SHEETS
1			3			S-27
2			4			37

DOCUMENT NOT CONSIDERED FINAL UNLESS ALL SIGNATURES COMPLETED

NOTES:

REPAIR LOCATIONS AND ESTIMATE OF QUANTITIES ARE GIVEN WITH THE BEST INFORMATION AVAILABLE. IF ADDITIONAL REPAIRS NOT SHOWN ON THE DRAWINGS ARE DEEMED NECESSARY BY THE INSPECTOR OR ENGINEER THE CONTRACTOR SHALL NOTE ON THE DRAWINGS THE APPROXIMATE LOCATION AND DESCRIPTION OF THE REPAIRS AND ADJUST THE ACTUAL QUANTITIES ENTERED INTO THE REPAIR QUANTITY TABLE.

FOR CAP AND COLUMN REPAIR DETAILS, SEE "TYPICAL CAP AND COLUMN REPAIR DETAILS" SHEET.

FOR SHOTCRETE REPAIRS, SEE SPECIAL PROVISIONS.

FOR EPOXY RESIN INJECTION, SEE SPECIAL PROVISIONS.

FOR EPOXY COATING, SEE SPECIAL PROVISIONS.

REPAIR QUANTITY TABLE

REPAIRS BENT 2	QUANTITIES			
	ESTIMATE		ACTUAL	
SHOTCRETE REPAIRS	AREA SF	VOLUME CF	AREA SF	VOLUME CF
CAP (VERTICAL FACE)	0.0	0.0		
CAP (HORIZONTAL, CORNER)	0.0	0.0		
COLUMN	0.0	0.0		
EPOXY RESIN INJECTION		LN. FT.		LN. FT.
CAP		10.0		
COLUMN		0.0		
EPOXY COATING	AREA SF			
TOP OF CAP	153.0			

VALUES IN CHART REPRESENT ESTIMATED REPAIR TOTALS AFTER REMOVAL OF UNSOUND CONCRETE, MIN. OF 1" BEHIND REBAR AND MIN. 2" CL TO SAWCUT. SEE REPAIR DETAILS.

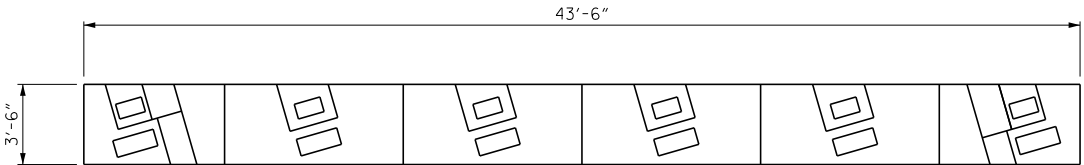

PLAN
TOP OF CAP



END VIEW
NORTH SIDE

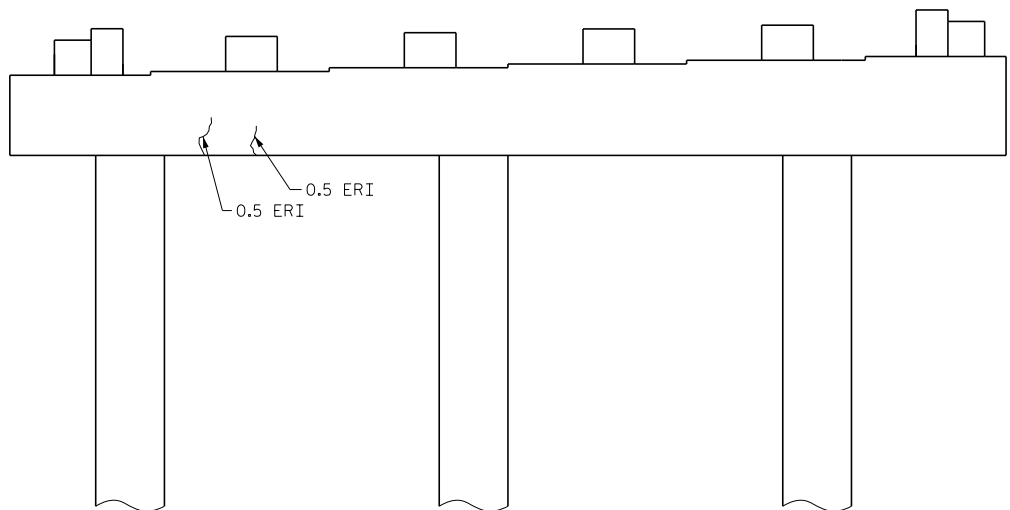

ELEVATION
WEST SIDE



END VIEW
SOUTH SIDE

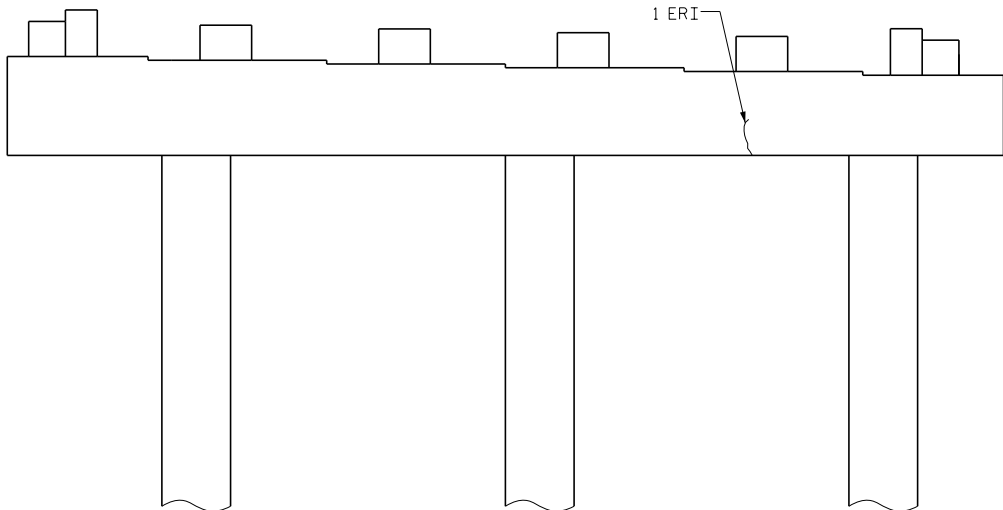

ELEVATION
EAST SIDE

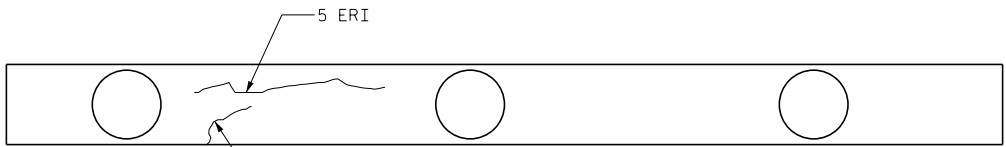

PLAN
BOTTOM OF CAP

▨ - CONCRETE REPAIR
ERI - EPOXY RESIN INJECTION

PROJECT NO. I-5977
JOHNSTON COUNTY
BRIDGE NO. 482

DocuSigned by:
Timothy M. Sherrill
AD50B1D97484CC...
PROFESSIONAL
SEAL
18565
ENGINEER
TIMOTHY M. SHERRILL

STATE OF NORTH CAROLINA
DEPARTMENT OF TRANSPORTATION
RALEIGH

SUBSTRUCTURE
BENT 2

2/28/2017

DRAWN BY : J. W. ARMFIELD / S. T. SANDOR DATE : 02/2017
CHECKED BY : W. C. SMITH DATE : 02/2017

DOCUMENT NOT CONSIDERED
FINAL UNLESS ALL
SIGNATURES COMPLETED

REVISIONS						SHEET NO.
NO.	BY:	DATE:	NO.	BY:	DATE:	TOTAL SHEETS
1			3			S-28
2			4			37

SUMMARY OF QUANTITIES

	ESTIMATE	ACTUAL
CONCRETE DECK REPAIR FOR EPOXY OVERLAY	*30 SQ. FT.	
EPOXY OVERLAY SYSTEM	6614.0 SQ. FT.	
BRIDGE JOINT DEMOLITION	166.5 SQ. FT.	

NOTE:

* CONCRETE DECK REPAIR FOR EPOXY OVERLAY IS NOT ANTICIPATED, TOKEN PAY ITEMS ARE INDICATED FOR PRICING PURPOSE IN CASE UNANTICIPATED REPAIR AREAS ARE ENCOUNTERED.



EPOXY OVERLAY



BRIDGE JOINT DEMOLITION

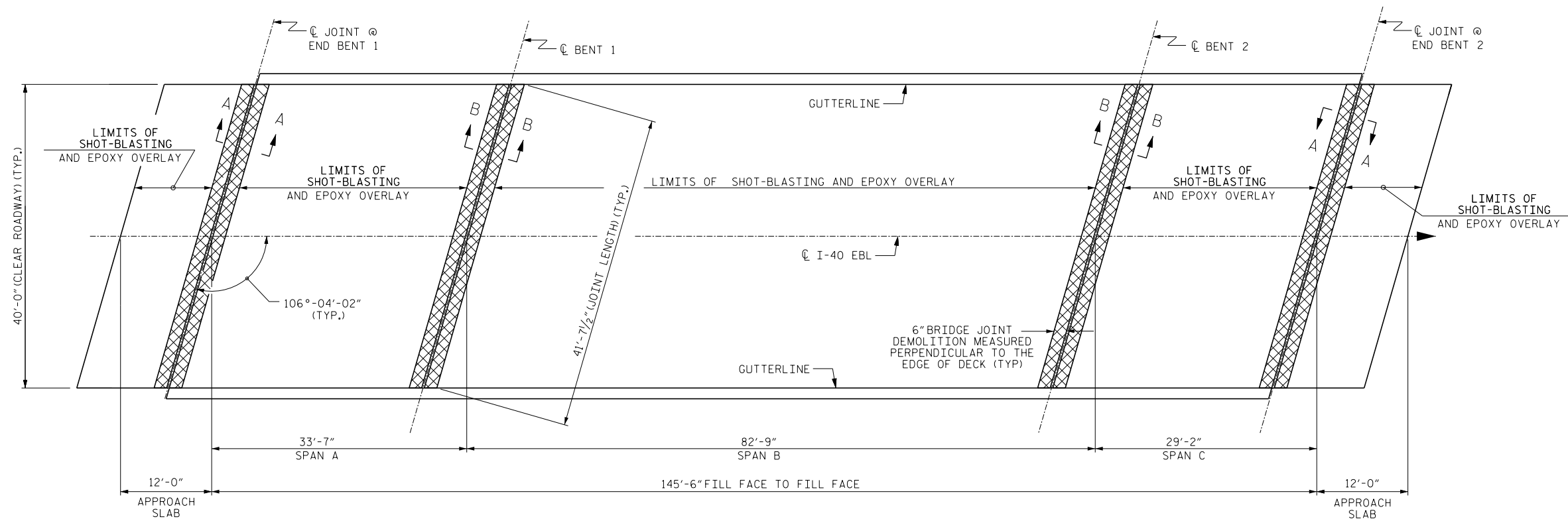

PLAN

(FOR SECTION A-A & B-B, SEE JOINT DETAIL SHEET S-32)

PROJECT NO. I-5977
JOHNSTON COUNTY
 BRIDGE NO. 483

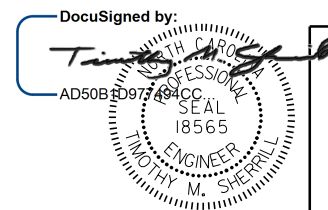

2/28/2017

STATE OF NORTH CAROLINA
 DEPARTMENT OF TRANSPORTATION
 RALEIGH

SUPERSTRUCTURE
 SURFACE PREPARATION
 & EPOXY OVERLAY

DRAWN BY : S. T. SANDOR DATE : 02/2017
 CHECKED BY : W. C. SMITH DATE : 02/2017

DOCUMENT NOT CONSIDERED
 FINAL UNLESS ALL
 SIGNATURES COMPLETED

REVISIONS						SHEET NO.
NO.	BY:	DATE:	NO.	BY:	DATE:	S-29
1			3			TOTAL SHEETS
2			4			37

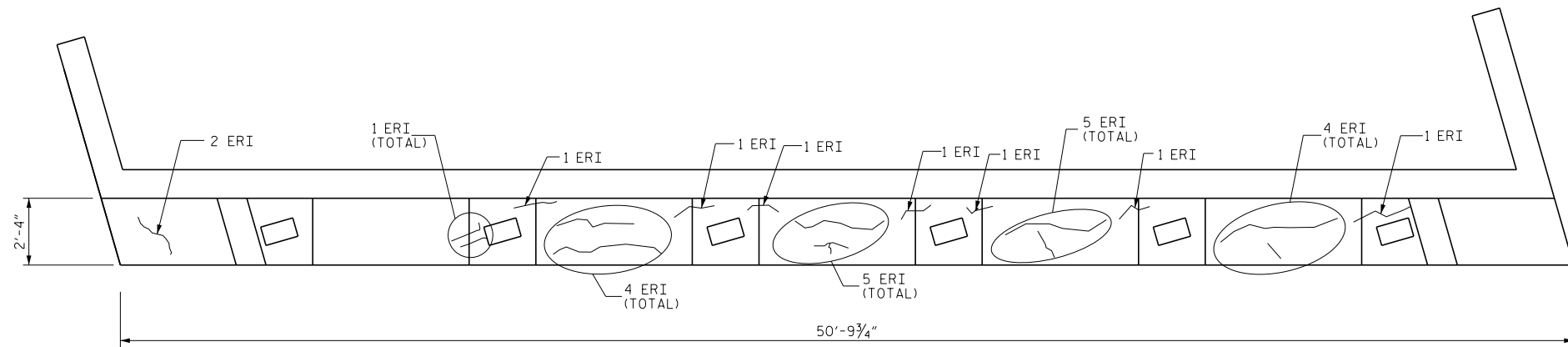

PLAN
END BENT 1

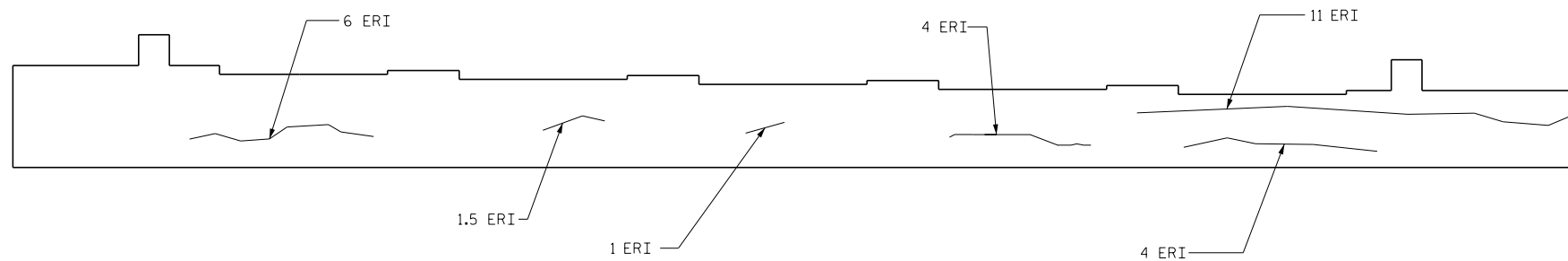

ELEVATION
END BENT 1

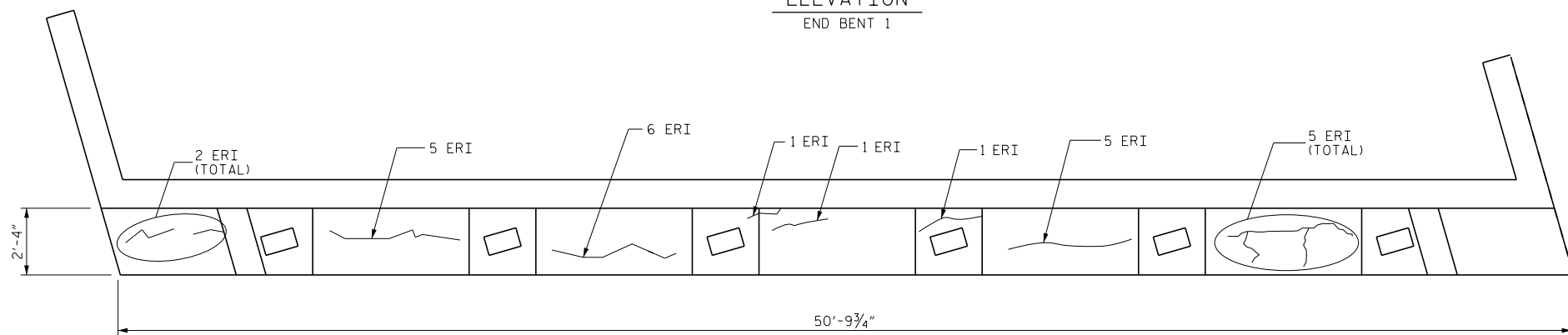

PLAN
END BENT 2

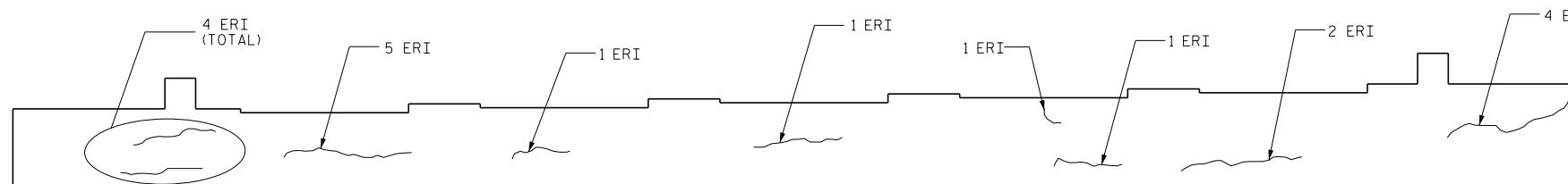

ELEVATION
END BENT 2

REPAIR QUANTITY TABLE

REPAIRS END BENT 1	QUANTITIES			
	ESTIMATE		ACTUAL	
SHOTCRETE REPAIRS	AREA SF	VOLUME CF	AREA SF	VOLUME CF
CAP (VERTICAL FACE)	0.0	0.0		
CAP (HORIZONTAL, CORNER)	0.0	0.0		
EPOXY RESIN INJECTION		LN. FT.	LN. FT.	
CAP		55.5		
EPOXY COATING		AREA SF		
TOP OF CAP		119.0		
REPAIRS END BENT 2	QUANTITIES			
	ESTIMATE		ACTUAL	
SHOTCRETE REPAIRS	AREA SF	VOLUME CF	AREA SF	VOLUME CF
CAP (VERTICAL FACE)	0.0	0.0		
CAP (HORIZONTAL, CORNER)	0.0	0.0		
EPOXY RESIN INJECTION		LN. FT.	LN. FT.	
CAP		45.0		
EPOXY COATING		AREA SF		
TOP OF CAP		119.0		

NOTES:

REPAIR LOCATIONS AND ESTIMATE OF QUANTITIES ARE GIVEN WITH THE BEST INFORMATION AVAILABLE. IF ADDITIONAL REPAIRS NOT SHOWN ON THE DRAWINGS ARE DEEMED NECESSARY BY THE INSPECTOR OR ENGINEER THE CONTRACTOR SHALL NOTE ON THE DRAWINGS THE APPROXIMATE LOCATION AND DESCRIPTION OF THE REPAIRS AND ADJUST THE ACTUAL QUANTITIES ENTERED INTO THE REPAIR QUANTITY TABLE.

FOR CAP AND COLUMN REPAIR DETAILS, SEE "TYPICAL CAP, COLUMN, AND RAIL REPAIR DETAILS" SHEET.

FOR SHOTCRETE REPAIRS, SEE SPECIAL PROVISIONS.

FOR EPOXY RESIN INJECTION, SEE SPECIAL PROVISIONS.

VALUES IN CHART REPRESENT ESTIMATED REPAIR TOTALS AFTER REMOVAL OF UNSOUND CONCRETE, MIN. OF 1" BEHIND REBAR AND MIN. 2" CL TO SAWCUT. SEE REPAIR DETAILS.

- SHOTCRETE REPAIR

ERI - EPOXY RESIN INJECTION

PROJECT NO. I-5977

JOHNSTON COUNTY

BRIDGE NO. 483

DocuSigned by:

AD50B15977484CC...
PROFESSIONAL
SEAL
18565
ENGINEER
TIMOTHY M. SHEPPARD

2/28/2017

STATE OF NORTH CAROLINA
DEPARTMENT OF TRANSPORTATION
RALEIGH

SUBSTRUCTURE

END BENTS

DRAWN BY : J. W. ARMFIELD / S. T. SANDOR DATE : 02/2017
CHECKED BY : W. C. SMITH DATE : 02/2017

27-FEB-2017 14:19
R:\Structures\15977 DGN\406_061_15977_SMU_530.EB .dgn
wsmith

DOCUMENT NOT CONSIDERED
FINAL UNLESS ALL
SIGNATURES COMPLETED

REVISIONS						SHEET NO.
NO.	BY:	DATE:	NO.	BY:	DATE:	TOTAL SHEETS
1			3			S-30
2			4			37

REPAIR QUANTITY TABLE

REPAIRS BENT 1	QUANTITIES			
	ESTIMATE		ACTUAL	
SHOTCRETE REPAIRS	AREA SF	VOLUME CF	AREA SF	VOLUME CF
CAP (VERTICAL FACE)	0.0	0.0		
CAP (HORIZONTAL, CORNER)	0.0	0.0		
COLUMN	0.0	0.0		
EPOXY RESIN INJECTION		LN. FT.		LN. FT.
CAP		17.0		
COLUMN		0.0		
EPOXY COATING	AREA SF			
TOP OF CAP	153.0			

VALUES IN CHART REPRESENT ESTIMATED REPAIR TOTALS AFTER REMOVAL OF UNSOUND CONCRETE, MIN. OF 1" BEHIND REBAR AND MIN. 2" CL TO SAWCUT. SEE REPAIR DETAILS.

NOTES:

REPAIR LOCATIONS AND ESTIMATE OF QUANTITIES ARE GIVEN WITH THE BEST INFORMATION AVAILABLE. IF ADDITIONAL REPAIRS NOT SHOWN ON THE DRAWINGS ARE DEEMED NECESSARY BY THE INSPECTOR OR ENGINEER THE CONTRACTOR SHALL NOTE ON THE DRAWINGS THE APPROXIMATE LOCATION AND DESCRIPTION OF THE REPAIRS AND ADJUST THE ACTUAL QUANTITIES ENTERED INTO THE REPAIR QUANTITY TABLE.

FOR CAP AND COLUMN REPAIR DETAILS, SEE "TYPICAL CAP, COLUMN, AND RAIL REPAIR DETAILS" SHEET.

FOR SHOTCRETE REPAIRS, SEE SPECIAL PROVISIONS.

FOR EPOXY RESIN INJECTION, SEE SPECIAL PROVISIONS.

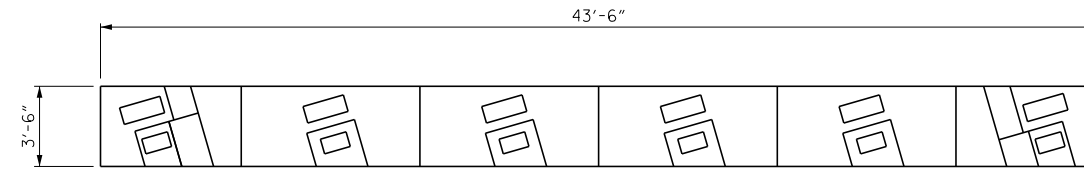

PLAN
TOP OF CAP

SPAN B
SPAN A

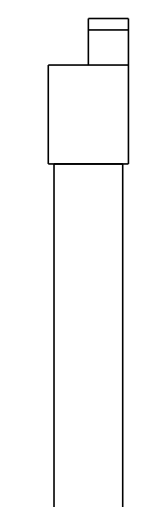

END VIEW
NORTH SIDE

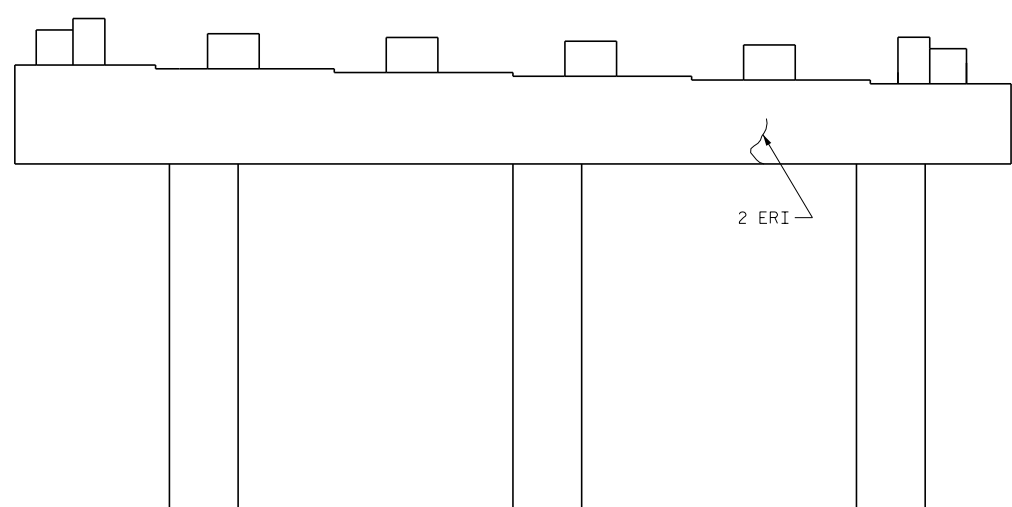

ELEVATION
WEST SIDE

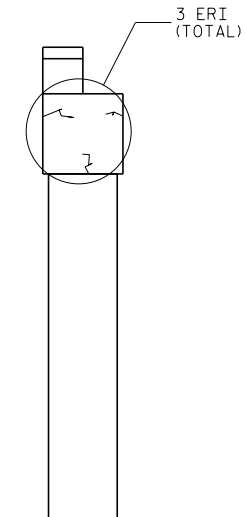

END VIEW
SOUTH SIDE

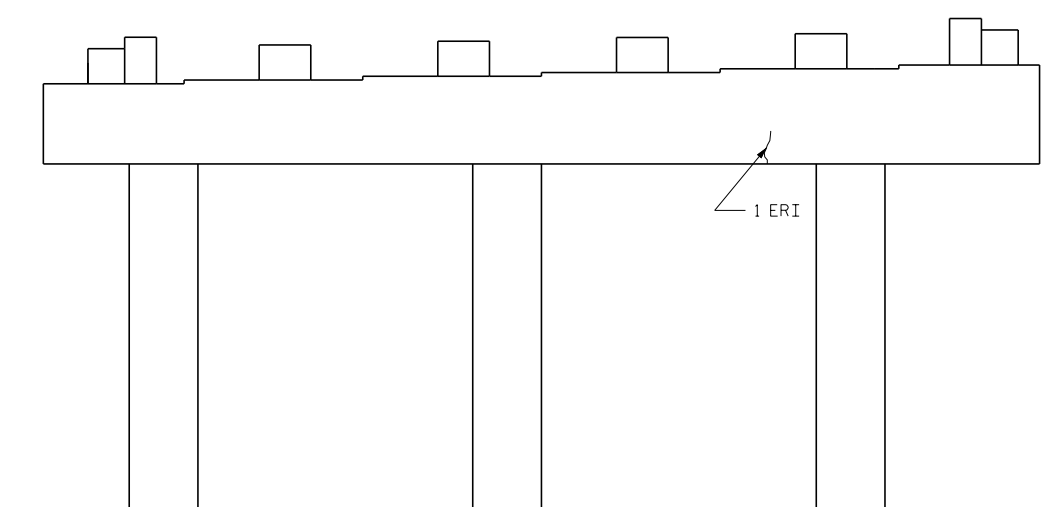

ELEVATION
EAST SIDE

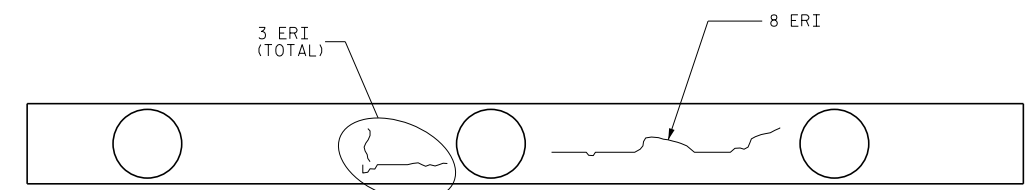

PLAN
BOTTOM OF CAP

- SHOTCRETE REPAIR
ERI - EPOXY RESIN INJECTION

PROJECT NO. I-5977
JOHNSTON COUNTY
BRIDGE NO. 483

DocuSigned by:
Timothy M. Sherrill
AD50B1D977484CC
PROFESSIONAL ENGINEER
SEAL
18565
TIMOTHY M. SHERRILL
2/28/2017

STATE OF NORTH CAROLINA
DEPARTMENT OF TRANSPORTATION
RALEIGH
SUBSTRUCTURE
BENT 1

DRAWN BY : J. W. ARMFIELD / S. T. SANDOR DATE : 02/2017
CHECKED BY : W. C. SMITH DATE : 02/2017

REVISIONS						SHEET NO.
NO.	BY:	DATE:	NO.	BY:	DATE:	S-31
1			3			TOTAL SHEETS
2			4			37

REPAIR QUANTITY TABLE

REPAIRS BENT 2	QUANTITIES			
	ESTIMATE		ACTUAL	
SHOTCRETE REPAIRS	AREA SF	VOLUME CF	AREA SF	VOLUME CF
CAP (VERTICAL FACE)	0.0	0.0		
CAP (HORIZONTAL, CORNER)	0.0	0.0		
COLUMN	0.0	0.0		
EPOXY RESIN INJECTION		LN. FT.		LN. FT.
CAP		3.0		
COLUMN		0.0		
EPOXY COATING		AREA SF		
TOP OF CAP		153.0		

VALUES IN CHART REPRESENT ESTIMATED REPAIR TOTALS AFTER REMOVAL OF UNSOUND CONCRETE, MIN. OF 1" BEHIND REBAR AND MIN. 2" CL TO SAWCUT. SEE REPAIR DETAILS.

NOTES:

REPAIR LOCATIONS AND ESTIMATE OF QUANTITIES ARE GIVEN WITH THE BEST INFORMATION AVAILABLE. IF ADDITIONAL REPAIRS NOT SHOWN ON THE DRAWINGS ARE DEEMED NECESSARY BY THE INSPECTOR OR ENGINEER THE CONTRACTOR SHALL NOTE ON THE DRAWINGS THE APPROXIMATE LOCATION AND DESCRIPTION OF THE REPAIRS AND ADJUST THE ACTUAL QUANTITIES ENTERED INTO THE REPAIR QUANTITY TABLE.

FOR CAP AND COLUMN REPAIR DETAILS, SEE "TYPICAL CAP, COLUMN, AND RAIL REPAIR DETAILS" SHEET.

FOR SHOTCRETE REPAIRS, SEE SPECIAL PROVISIONS.

FOR EPOXY RESIN INJECTION, SEE SPECIAL PROVISIONS.

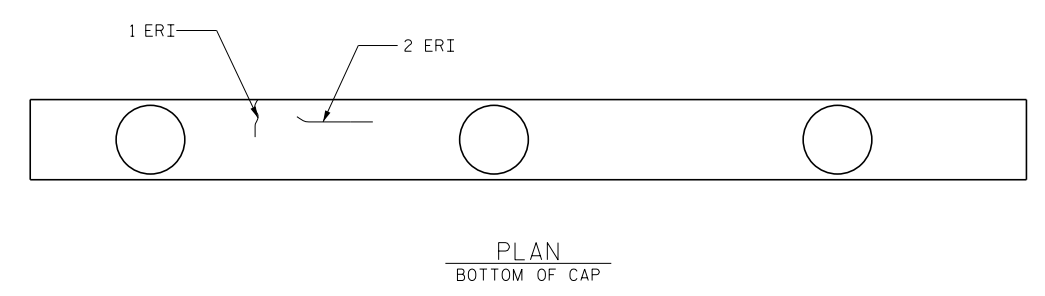
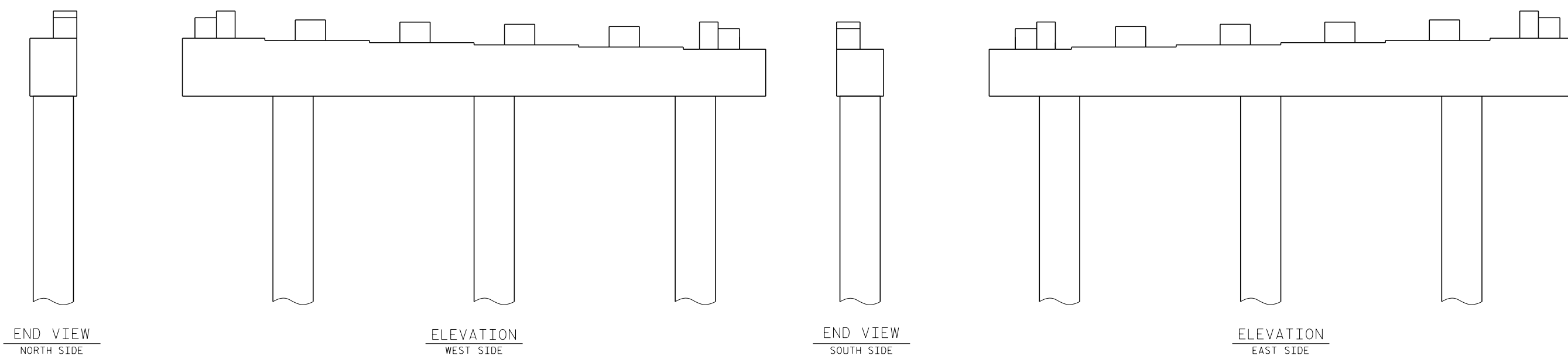
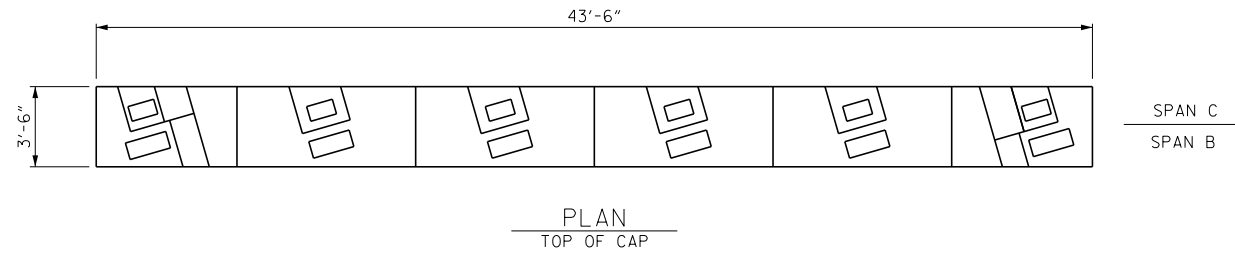

▨ - SHOTCRETE REPAIR
ERI - EPOXY RESIN INJECTION

PROJECT NO. I-5977
JOHNSTON COUNTY
BRIDGE NO. 483

DocuSigned by:
Timothy M. Sherrill
AD50B1B077494CC
PROFESSIONAL
SEAL
18565
ENGINEER
TIMOTHY M. SHERRILL
2/28/2017

STATE OF NORTH CAROLINA
DEPARTMENT OF TRANSPORTATION
RALEIGH
SUBSTRUCTURE
BENT 2

DRAWN BY : J. W. ARMFIELD / S. T. SANDOR DATE : 02/2017
CHECKED BY : W. C. SMITH DATE : 02/2017

REVISIONS						SHEET NO.
NO.	BY:	DATE:	NO.	BY:	DATE:	TOTAL SHEETS
1			3			S-32
2			4			37

DOCUMENT NOT CONSIDERED FINAL UNLESS ALL SIGNATURES COMPLETED

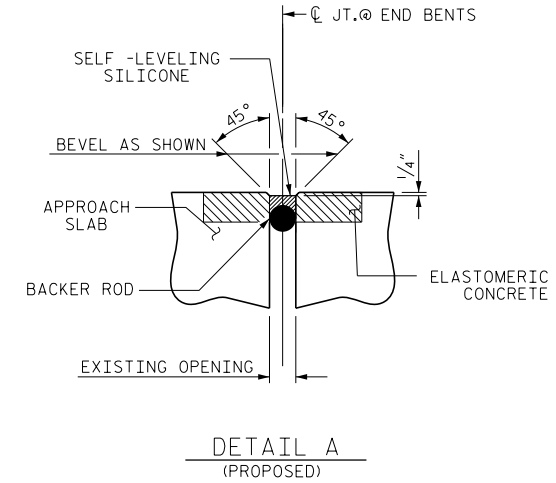
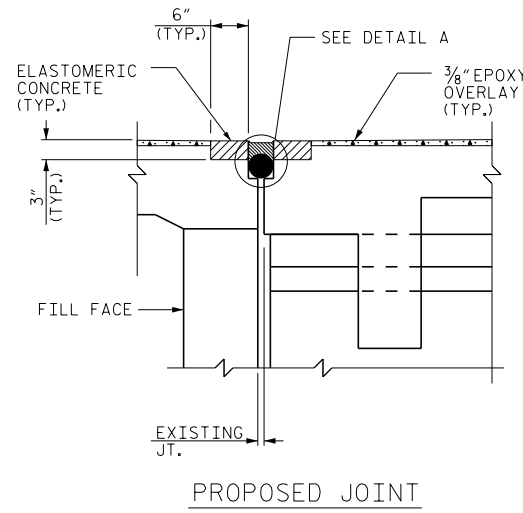
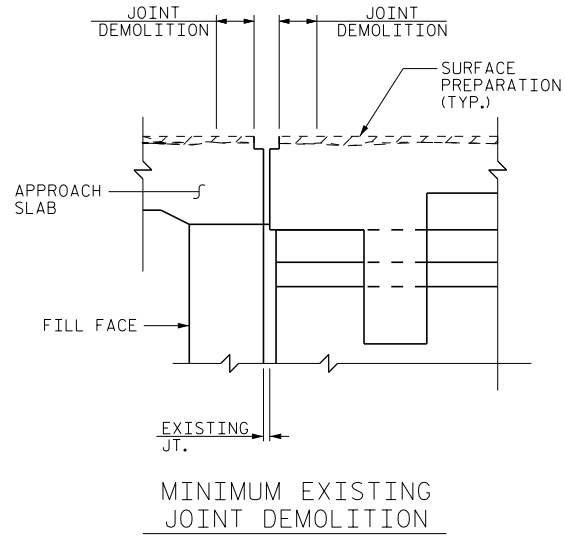
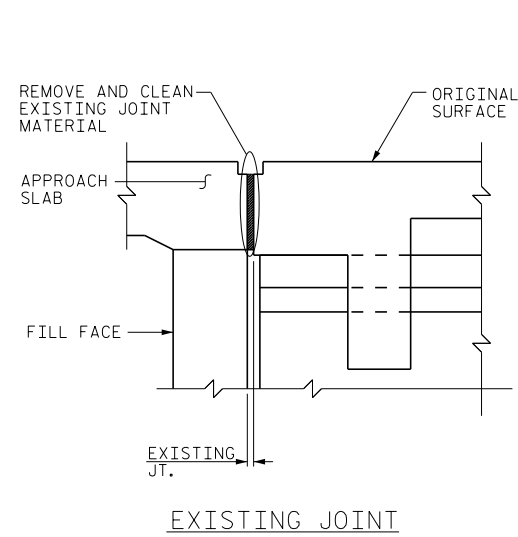

NOTES:
 CONTRACTOR SHALL FIELD VERIFY THE EXISTING FORMED OPENING PRIOR TO OBTAINING JOINT MATERIAL.
 FOR SILICONE JOINT SEALANT, SEE SPECIAL PROVISIONS.
 FOR ELASTOMERIC CONCRETE, SEE SPECIAL PROVISIONS.
 RETAIN ALL EXISTING REINFORCING STEEL. CLEAN AND REPAIR AS NEEDED.

JOINT INSTALLATION SEQUENCE AT END BENTS

SECTION A-A

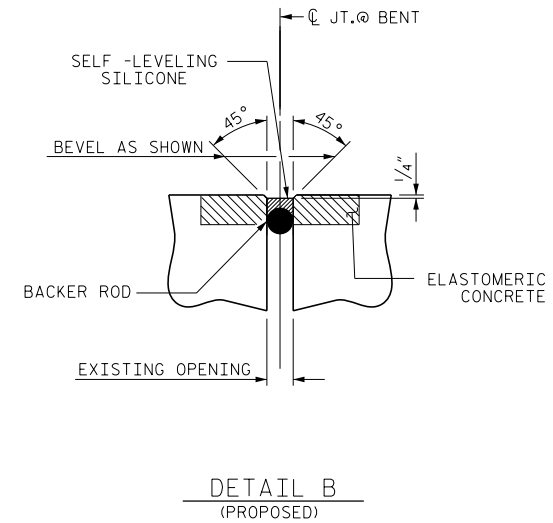
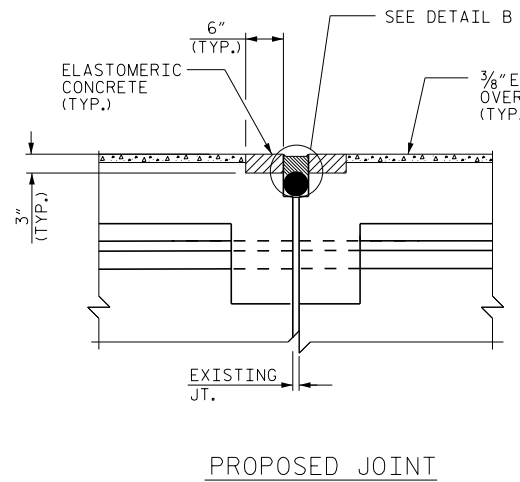
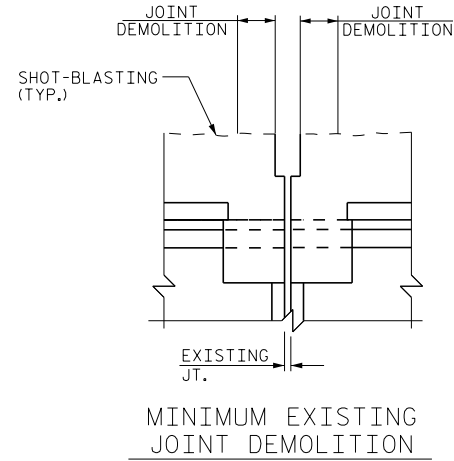
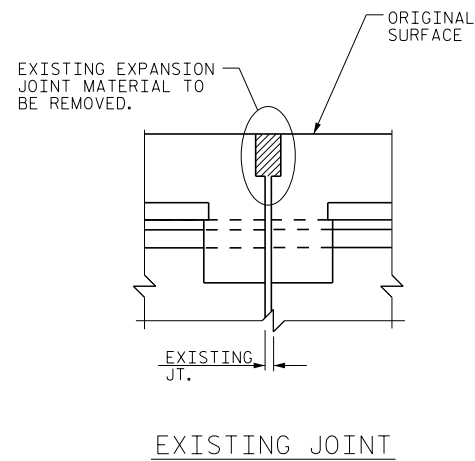

JOINT INSTALLATION SEQUENCE AT BENTS

SECTION B-B

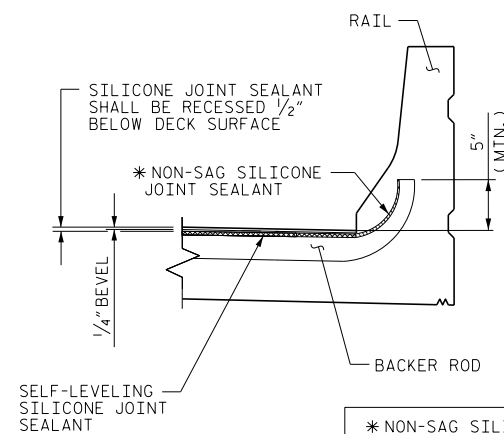
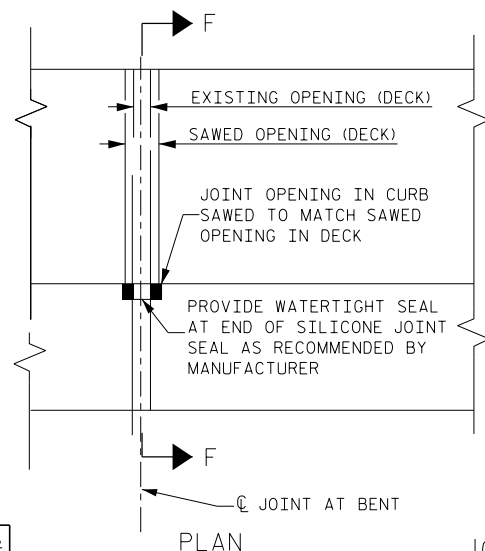

*NON-SAG SILICONE JOINT SEALANT TO BE PLACED AND ALLOWED TO SET, PRIOR TO PLACEMENT OF SELF-LEVELING SILICONE JOINT SEALANT.

SECTION F-F

PROJECT NO. I-5977
 JOHNSTON COUNTY
 BRIDGE NO.: 482 & 483

STATE OF NORTH CAROLINA
 DEPARTMENT OF TRANSPORTATION
 RALEIGH

JOINT DETAILS

DRAWN BY : M. WELDON / S.T. SANDOR DATE : 10/2016
 CHECKED BY : W.C. SMITH DATE : 02/2017

DocuSigned by:
 Timothy M. Sheppard
 AD50B1997749CC...
 PROFESSIONAL SEAL
 18565
 ENGINEER
 TIMOTHY M. SHEPPARD
 2/28/2017

DOCUMENT NOT CONSIDERED FINAL UNLESS ALL SIGNATURES COMPLETED

REVISIONS						SHEET NO.
NO.	BY:	DATE:	NO.	BY:	DATE:	S-33
1			3			TOTAL SHEETS
2			4			37

GIRDER REPAIR TABLE			
SPAN	GIRDER	LOCATION	REPAIR SIZE
A	1	IN WEB @ END BENT 1	5.0' ERI
A	1	CONCRETE REPAIR IN WEB	2.5 SQ FT
A	2	IN WEB @ END BENT 1	1.5' ERI
A	3	IN WEB @ END BENT 1	2.0' ERI
A	4	IN WEB @ END BENT 1	1.5' ERI
A	5	IN WEB @ END BENT 1	3.0' ERI
A	6	IN WEB @ END BENT 1	8.0' ERI
A	1	IN WEB @ BENT 1	3.0' ERI
A	3	IN WEB @ BENT 1	1.0' ERI
A	6	IN WEB @ BENT 1	9.0' ERI
B	1	IN WEB @ BENT 1	5.0' ERI
B	2	IN WEB @ BENT 1	1.0' ERI
B	3	IN WEB @ BENT 1	3.0' ERI
B	4	IN WEB @ BENT 1	2.0' ERI
B	4	TOP FLANGE CONCRETE REPAIR @ BENT 1	1.0 SQ FT
B	6	IN WEB @ BENT 1	4.0' ERI
B	1	IN WEB @ BENT 2	5.5' ERI
B	2	IN WEB @ BENT 2	1.0' ERI
B	4	IN WEB @ BENT 2	0.5' ERI
B	5	IN WEB @ BENT 2	1.0' ERI
B	6	IN WEB @ BENT 2	4.0' ERI
C	2	IN WEB @ BENT 2	1.0' ERI
C	3	CONCRETE REPAIR IN WEB @ BENT 2	1.0 SQ FT
C	6	IN WEB @ BENT 2	2.0' ERI
C	1	IN WEB @ END BENT 2	7.0' ERI
C	1	CONCRETE REPAIR IN WEB @ END BENT 2	2.0 SQ FT
C	2	IN WEB @ END BENT 2	4.0' ERI
C	2	CONCRETE REPAIR IN WEB @ END BENT 2	0.5 SQ FT
C	3	IN WEB @ END BENT 2	0.5' ERI
C	3	CONCRETE REPAIR IN WEB @ END BENT 2	0.75 SQ FT
C	4	CONCRETE REPAIR IN WEB @ END BENT 2	0.75 SQ FT
C	5	CONCRETE REPAIR IN WEB @ END BENT 2	0.75 SQ FT

REPAIR QUANTITY TABLE				
	QUANTITIES			
	ESTIMATE		ACTUAL	
SHOTCRETE REPAIRS	AREA SF	VOLUME CF	AREA SF	VOLUME CF
GIRDER	9.2	4.6		
SLAB	6.0	3.0		
PRECAST DECK PANEL	0.0	0.0		
EPOXY RESIN INJECTION	LN. FT.		LN. FT.	
GIRDER	75.5			
SLAB	34.0			
PRECAST DECK PANEL	3.0			

VALUES IN CHART REPRESENT ESTIMATED REPAIR TOTALS AFTER REMOVAL OF UNSOUND CONCRETE, MIN. OF 1" BEHIND REBAR AND MIN. 2" CL TO SAWCUT. SEE REPAIR DETAILS.

NOTES:

FOR CAP AND COLUMN REPAIR DETAILS, SEE "TYPICAL CAP, COLUMN, AND RAIL REPAIR DETAILS" SHEET.

FOR SHOTCRETE REPAIRS, SEE SPECIAL PROVISIONS.

FOR EPOXY RESIN INJECTION, SEE SPECIAL PROVISIONS.

FOR GIRDER REPAIR DETAILS, SEE "GIRDER REPAIR DETAILS" SHEET.

UNDERDECK & DIAPHRAGM REPAIR TABLE			
SPAN	BAY	LOCATION	REPAIR SIZE
A, B, C		EDGE OF SLAB @ NORTH OVERHANG	24.0' ERI
A, B, C		EDGE OF SLAB @ SOUTH OVERHANG	10.0' ERI
B	1	8' FROM BENT 2 IN PRECAST DECK PANEL	3.0' ERI
B & C		CONCRETE REPAIR IN BOTTOM OF SLAB, BENT 2 @ NORTH OVERHANG	6.0 SQ FT

PROJECT NO. I-5977
JOHNSTON COUNTY
BRIDGE NO. 482

DocuSigned by:

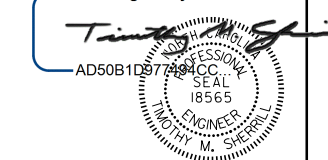

2/28/2017

STATE OF NORTH CAROLINA DEPARTMENT OF TRANSPORTATION RALEIGH				
SHOTCRETE REPAIR & CRACK INJECTION TABLES				
REVISIONS				SHEET NO.
NO.	BY:	DATE:	NO.	BY:
1			3	
2			4	
				TOTAL SHEETS
				S-34
				37

DRAWN BY : J. W. ARMFIELD / S. T. SANDOR DATE : 02 / 2017
CHECKED BY : W. C. SMITH DATE : 02 / 2017

DOCUMENT NOT CONSIDERED
FINAL UNLESS ALL
SIGNATURES COMPLETED

GIRDER REPAIR TABLE			
SPAN	GIRDER	LOCATION	REPAIR SIZE
A	1	IN WEB @ END BENT 1	2.0' ERI
A	2	IN WEB @ END BENT 1	1.0' ERI
A	3	IN WEB @ END BENT 1	2.0' ERI
A	4	IN WEB @ END BENT 1	3.0' ERI
A	5	IN WEB @ END BENT 1	5.0' ERI
A	6	IN WEB @ END BENT 1	7.0' ERI
A	1	IN WEB @ BENT 1	2.0' ERI
A	4	IN WEB @ BENT 1	1.0' ERI
A	6	IN WEB @ BENT 1	3.0' ERI
B	1	IN WEB @ BENT 1	1.0' ERI
B	2	IN WEB @ BENT 1	1.0' ERI
B	5	IN WEB @ BENT 1	1.0' ERI
B	6	IN WEB @ BENT 1	4.0' ERI
B	1	IN WEB @ BENT 2	2.0' ERI
B	3	CONCRETE REPAIR IN SIDE OF BOTTOM FLANGE @ BENT 2	1.3 SQ FT
B	3	CONCRETE REPAIR IN WEB @ BENT 2	1.0 SQ FT
B	5	IN WEB @ BENT 2	1.0' ERI
B	6	IN WEB @ BENT 2	8.0' ERI
B	6	CONCRETE REPAIR IN WEB @ BENT 2	3.0 SQ FT
C	1	IN WEB @ BENT 2	7.0' ERI
C	2	IN WEB @ BENT 2	2.0' ERI
C	3	IN WEB @ BENT 2	1.0' ERI
C	4	IN WEB @ BENT 2	3.0' ERI
C	5	IN WEB @ BENT 2	1.0' ERI
C	6	IN WEB @ BENT 2	9.0' ERI
C	1	IN WEB @ END BENT 2	5.0' ERI
C	2	IN WEB @ END BENT 2	3.0' ERI
C	3	IN WEB @ END BENT 2	1.0' ERI
C	3	CONCRETE REPAIR IN WEB @ END BENT 2	2.0 SQ FT
C	4	IN WEB @ END BENT 2	3.0' ERI
C	5	IN WEB @ END BENT 2	3.0' ERI
C	6	IN WEB @ END BENT 2	4.0' ERI

REPAIR QUANTITY TABLE				
	QUANTITIES			
	ESTIMATE		ACTUAL	
SHOTCRETE REPAIRS	AREA SF	VOLUME CF	AREA SF	VOLUME CF
GIRDER	7.3	3.7		
SLAB	0.0	0.0		
PRECAST DECK PANEL	0.0	0.0		
EPOXY RESIN INJECTION	LN. FT.		LN. FT.	
GIRDER	86.0			
SLAB	0.0			
PRECAST DECK PANEL	3.0			

VALUES IN CHART REPRESENT ESTIMATED REPAIR TOTALS AFTER REMOVAL OF UNSOUND CONCRETE, MIN. OF 1" BEHIND REBAR AND MIN. 2" CL TO SAWCUT. SEE REPAIR DETAILS.

NOTES:
 FOR CAP AND COLUMN REPAIR DETAILS, SEE "TYPICAL CAP, COLUMN, AND RAIL REPAIR DETAILS" SHEET.
 FOR SHOTCRETE REPAIRS, SEE SPECIAL PROVISIONS.
 FOR EPOXY RESIN INJECTION, SEE SPECIAL PROVISIONS.
 FOR GIRDER REPAIR DETAILS, SEE "GIRDER REPAIR DETAILS" SHEET.

UNDERDECK & DIAPHRAGM REPAIR TABLE			
SPAN	BAY	LOCATION	REPAIR SIZE
C	5	BENT 2 IN PRECAST DECK PANEL	3.0' ERI

PROJECT NO. I-5977
JOHNSTON COUNTY
 BRIDGE NO. 483

DocuSigned by:

 AD50B18977484CC
 18565
 ENGINEER
 TIMOTHY M. SHERRILL

STATE OF NORTH CAROLINA
 DEPARTMENT OF TRANSPORTATION
 RALEIGH
 SHOTCRETE REPAIR
 & CRACK INJECTION
 TABLES

2/28/2017

DRAWN BY : J. W. ARMFIELD DATE : 11/3/15
 CHECKED BY : W. M. CLARKE DATE : 2/2017

REVISIONS						SHEET NO.
NO.	BY:	DATE:	NO.	BY:	DATE:	TOTAL SHEETS
1			3			37
2			4			

DOCUMENT NOT CONSIDERED
 FINAL UNLESS ALL
 SIGNATURES COMPLETED

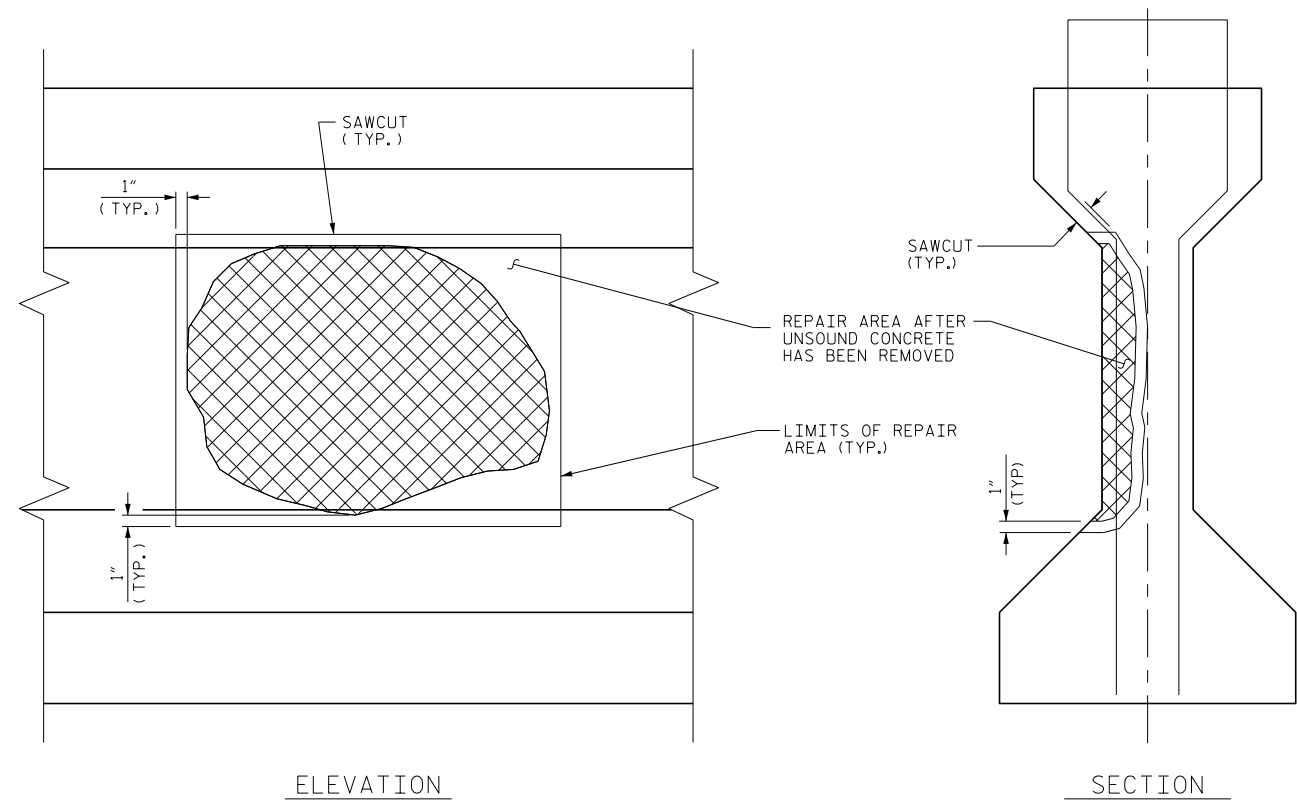

GIRDER WEB REPAIR

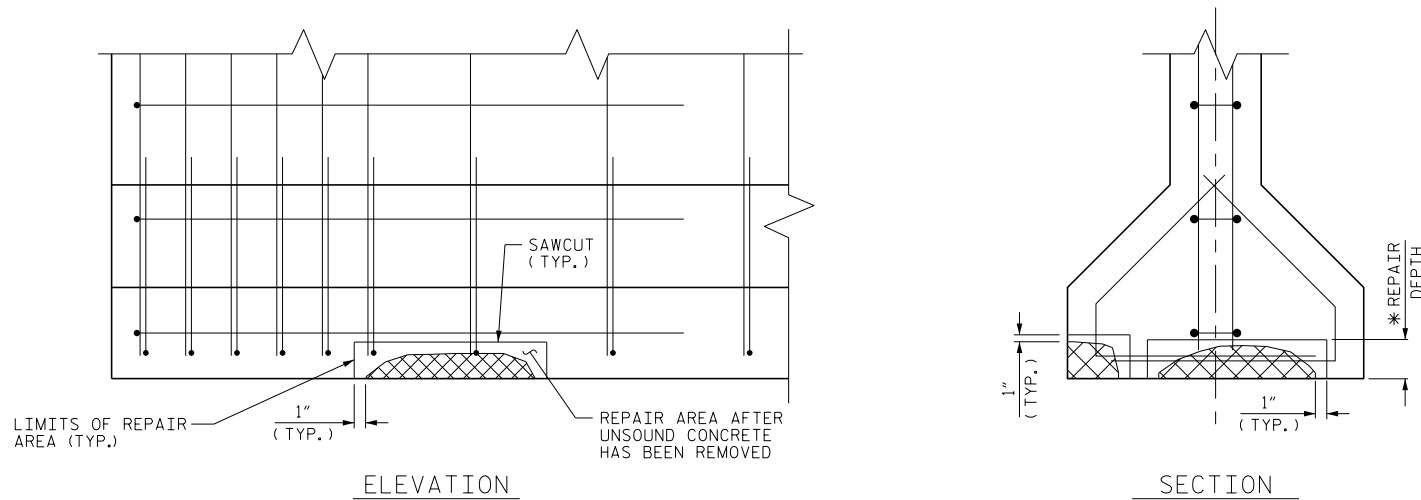

GIRDER FLANGE REPAIR

NOTES:

EXISTING REINFORCING STEEL LOCATIONS ARE FROM BEST INFORMATION AVAILABLE.

AROUND THE PERIMETER OF THE REPAIR AREA, AS INDICATED, THE CONTRACTOR SHALL SAW CUT TO A MINIMUM DEPTH OF 1/2" BUT REINFORCING STEEL AND PRESTRESSING STRANDS SHALL NOT BE DAMAGED.

THE CONTRACTOR SHALL REMOVE SURFACE CONCRETE TO VERIFY THAT SAW CUT DEPTH WILL NOT DAMAGE EXISTING REINFORCING STEEL AND PRESTRESSING STRANDS.

AFTER REMOVAL OF SOUND AND UNSOUND CONCRETE WITHIN THE SAWCUT AREA, TO A MINIMUM DEPTH OF 1/2", CLEAN AND REMOVE RUST FROM ALL REINFORCING STEEL AND PRESTRESSING STRANDS.

SHOTCRETE OR CONCRETE MAY BE USED FOR REPAIRS WITH THE APPROVAL OF THE ENGINEER.

MAXIMUM AGGREGATE SIZE FOR REPAIR MATERIAL SHALL NOT EXCEED 2/3 THE MINIMUM REPAIR DEPTH.

FOR SHOTCRETE REPAIRS, SEE SPECIAL PROVISIONS.

* REPAIR DEPTH:

IF REMOVAL OF UNSOUND CONCRETE RESULTS IN EXPOSING MORE THAN HALF THE DEPTH OF A REINFORCING BAR OR PRESTRESSING STRAND, REMOVE ADDITIONAL CONCRETE TO 1" BEHIND THE BAR OR STRAND WITHOUT DAMAGE TO REINFORCING BAR OR PRESTRESSING STRAND. ALTERNATIVELY, AS DIRECTED BY THE ENGINEER, INSTALL 1/4" DIAMETER X 3" LONG (MAX.) ADHESIVE ANCHORS OR STUDS IN REPAIR AREAS WITH MINIMUM DEPTH OF 1/2" WITHOUT DAMAGE TO REINFORCING BAR OR PRESTRESSING STRAND.

PROJECT NO. I-5977
 HALIFAX & JOHNSTON COUNTIES
 BRIDGE NO. 12, 13, 482
 & 483

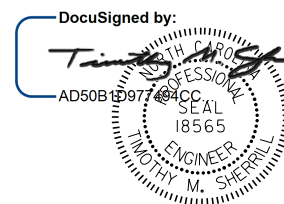

2/28/2017

STATE OF NORTH CAROLINA
 DEPARTMENT OF TRANSPORTATION
 RALEIGH

GIRDER REPAIR
 DETAILS

DRAWN BY : J. W. ARMFIELD / S. T. SANDOR DATE : 02/2017
 CHECKED BY : W. C. SMITH DATE : -

DOCUMENT NOT CONSIDERED
 FINAL UNLESS ALL
 SIGNATURES COMPLETED

REVISIONS						SHEET NO.
NO.	BY:	DATE:	NO.	BY:	DATE:	S-36
1			3			TOTAL SHEETS
2			4			37

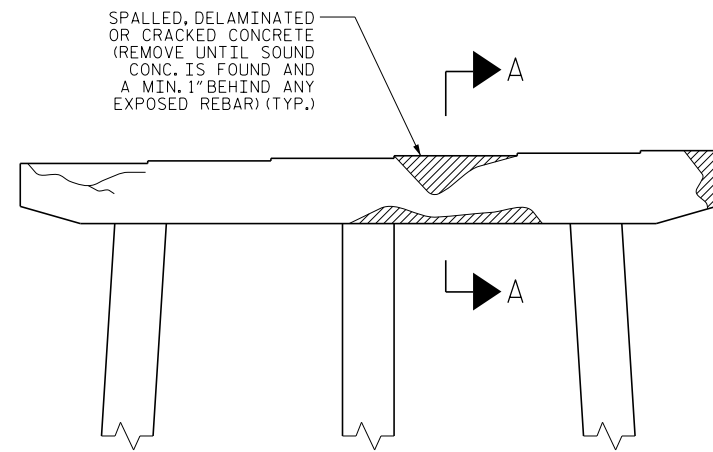

BENT CAP REPAIRS

SPALLED, DELAMINATED OR CRACKED CONCRETE (REMOVE UNTIL SOUND CONC. IS FOUND AND A MIN. 1" BEHIND ANY EXPOSED REBAR). EXTENT OF REPAIR SHALL NOT EXCEED 1/3 OF THE COLUMN CIRCUMFERENCE AT ONE TIME, UNLESS APPROVED BY THE ENGINEER.

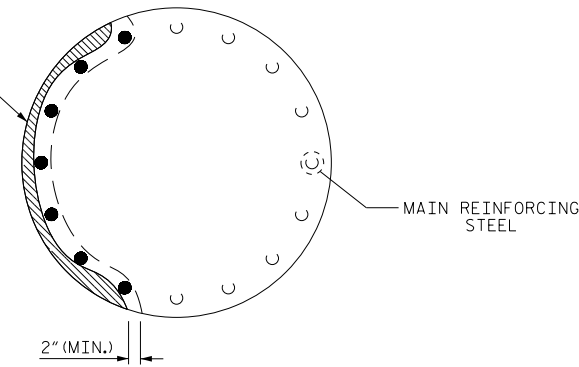

PLAN OF COLUMN

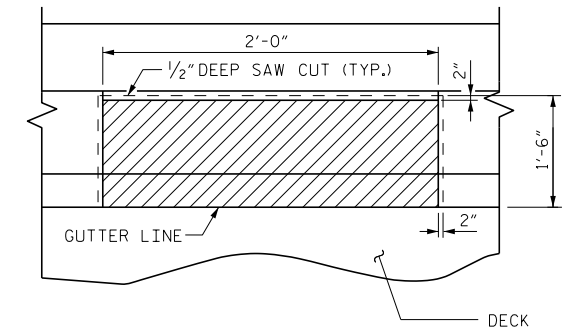

ELEVATION

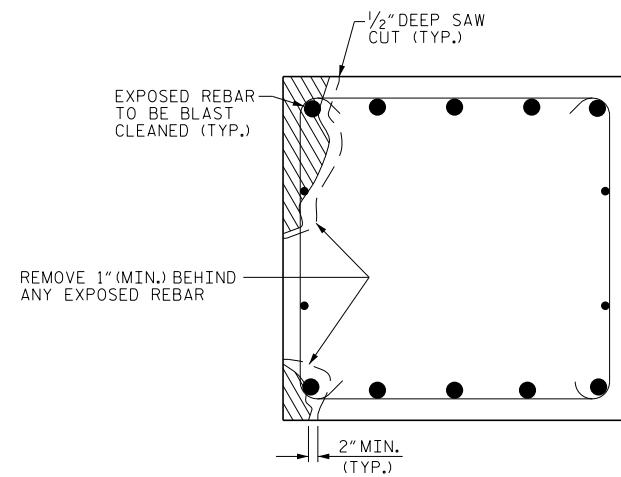

SECTION THRU CAP

CAP REPAIR

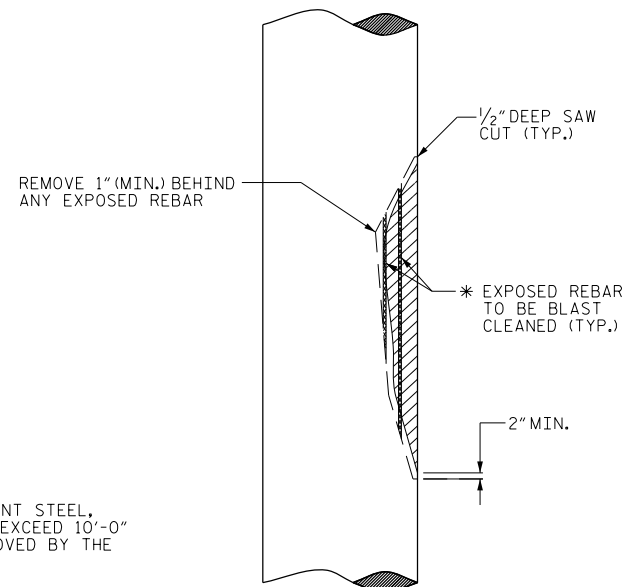

ELEVATION OF COLUMN

COLUMN REPAIR

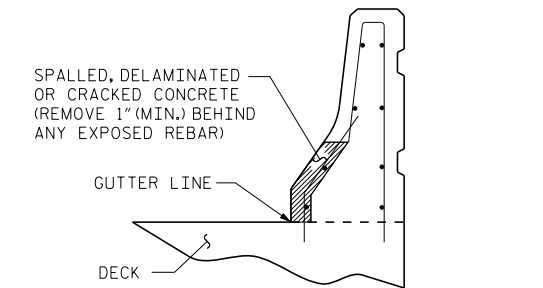

SECTION THRU BARRIER RAIL
EXPOSED REBAR TO BE CLEANED

CONCRETE BARRIER RAIL REPAIR

(BRIDGES #482 & #483)

* DUE TO LACK OF CONFINEMENT STEEL, REPAIR LENGTH SHALL NOT EXCEED 10'-0" AT ONE TIME, UNLESS APPROVED BY THE ENGINEER.

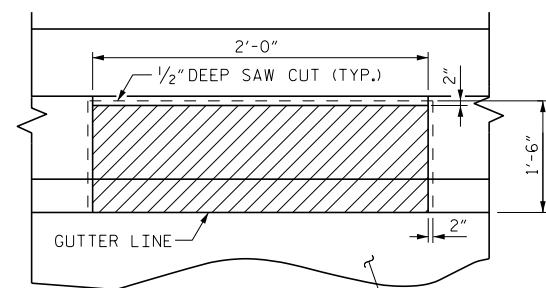

ELEVATION

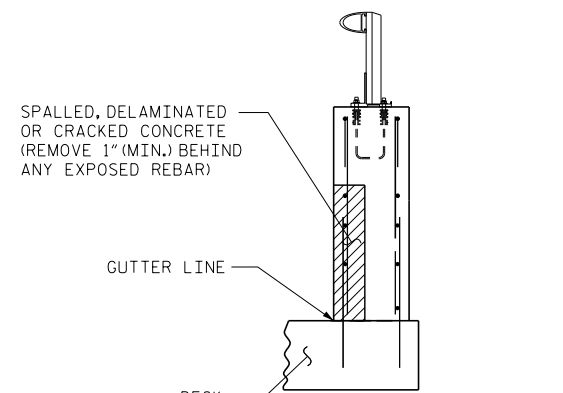

SECTION THRU BARRIER RAIL
EXPOSED REBAR TO BE BLAST CLEANED

CONCRETE BARRIER RAIL REPAIR

(BRIDGES #12 & #13)

PROJECT NO. I-5977
 HALIFAX & JOHNSTON COUNTIES
 BRIDGE NO. 12, 13, 482
 & 483

DocuSigned by:
Timothy M. Shear
 AD50B1D977494CC
 PROFESSIONAL SEAL
 18565
 ENGINEER
 TIMOTHY M. SHEAR

2/28/2017

STATE OF NORTH CAROLINA
 DEPARTMENT OF TRANSPORTATION
 RALEIGH
 TYPICAL
 CAP, COLUMN, AND RAIL
 REPAIR DETAILS

DRAWN BY : S. T. SANDOR DATE : 02/2017
 CHECKED BY : W. C. SMITH DATE : 02/2017

DOCUMENT NOT CONSIDERED
 FINAL UNLESS ALL
 SIGNATURES COMPLETED

REVISIONS						SHEET NO.
NO.	BY:	DATE:	NO.	BY:	DATE:	TOTAL SHEETS
1			3			37
2			4			37

STANDARD NOTES

DESIGN DATA:

SPECIFICATIONS	-----	A.A.S.H.T.O. (CURRENT)
LIVE LOAD	-----	SEE PLANS
IMPACT ALLOWANCE	-----	SEE A.A.S.H.T.O.
STRESS IN EXTREME FIBER OF		
STRUCTURAL STEEL - AASHTO M270 GRADE 36	-	20,000 LBS. PER SQ. IN.
- AASHTO M270 GRADE 50W	-	27,000 LBS. PER SQ. IN.
- AASHTO M270 GRADE 50	-	27,000 LBS. PER SQ. IN.
REINFORCING STEEL IN TENSION		
GRADE 60	--	24,000 LBS. PER SQ. IN.
CONCRETE IN COMPRESSION	-----	1,200 LBS. PER SQ. IN.
CONCRETE IN SHEAR	-----	SEE A.A.S.H.T.O.
STRUCTURAL TIMBER - TREATED OR		
UNTREATED - EXTREME FIBER STRESS	-----	1,800 LBS. PER SQ. IN.
COMPRESSION PERPENDICULAR TO GRAIN OF TIMBER	-----	375 LBS. PER SQ. IN.
EQUIVALENT FLUID PRESSURE OF EARTH	-----	30 LBS. PER CU. FT. (MINIMUM)

MATERIAL AND WORKMANSHIP:

EXCEPT AS MAY OTHERWISE BE SPECIFIED ON PLANS OR IN THE SPECIAL PROVISIONS, ALL MATERIAL AND WORKMANSHIP SHALL BE IN ACCORDANCE WITH THE 2012 "STANDARD SPECIFICATIONS FOR ROADS AND STRUCTURES" OF THE N. C. DEPARTMENT OF TRANSPORTATION.

STEEL SHEET PILING FOR PERMANENT OR TEMPORARY APPLICATIONS SHALL BE HOT ROLLED.

CONCRETE:

UNLESS OTHERWISE REQUIRED ON PLANS, CLASS A CONCRETE SHALL BE USED FOR ALL PORTIONS OF ALL STRUCTURES WITH THE EXCEPTION THAT: CLASS AA CONCRETE SHALL BE USED IN BRIDGE SUPERSTRUCTURES, ABUTMENT BACKWALLS, AND APPROACH SLABS; AND CLASS B CONCRETE SHALL BE USED FOR SLOPE PROTECTION AND RIP RAP.

CONCRETE CHAMFERS:

UNLESS OTHERWISE NOTED ON THE PLANS, ALL EXPOSED CORNERS ON STRUCTURES SHALL BE CHAMFERED 3/4" WITH THE FOLLOWING EXCEPTIONS: TOP CORNERS OF CURBS MAY BE ROUNDED TO 1-1/2" RADIUS WHICH IS BUILT INTO CURB FORMS; CORNERS OF TRANSVERSE FLOOR EXPANSION JOINTS SHALL BE ROUNDED WITH A 1/4" FINISHING TOOL UNLESS OTHERWISE REQUIRED ON PLANS; AND CORNERS OF EXPANSION JOINTS IN THE ROADWAY FACES AND TOPS OF CURBS AND SIDEWALKS SHALL BE ROUNDED TO A 1/4" RADIUS WITH A FINISHING STONE OR TOOL UNLESS OTHERWISE REQUIRED ON PLANS.

DOWELS:

DOWELS WHEN INDICATED ON PLANS AS FOR CULVERT EXTENSIONS, SHALL BE EMBEDDED AT LEAST 12" INTO THE OLD CONCRETE AND GROUTED INTO PLACE WITH 1:2 CEMENT MORTAR.

ALLOWANCE FOR DEAD LOAD DEFLECTION, SETTLEMENT, ETC. IN CASTING SUPERSTRUCTURES:

BRIDGES SHALL BE BUILT ON THE GRADE OR VERTICAL CURVE SHOWN ON PLANS. SLABS, CURBS AND PARAPETS SHALL CONFORM TO THE GRADE OR CURVE. ALL DIMENSIONS WHICH ARE GIVEN IN SECTION AND ARE AFFECTED BY DEAD LOAD DEFLECTIONS ARE DIMENSIONS AT CENTER LINE OF BEARING UNLESS OTHERWISE NOTED ON PLANS. IN SETTING FORMS FOR STEEL BEAM BRIDGES AND PRESTRESSED CONCRETE GIRDER BRIDGES, ADJUSTMENTS SHALL BE MADE DUE TO THE DEAD LOAD DEFLECTIONS FOR THE ELEVATIONS SHOWN. WHERE BLOCKS ARE SHOWN OVER BEAMS FOR BUILDING UP TO THE SLAB, THE VERTICAL DIMENSIONS OF THE BLOCKS SHALL BE ADJUSTED BETWEEN BEARINGS TO COMPENSATE FOR DEAD LOAD DEFLECTIONS, VERTICAL CURVE ORDINATE, AND ACTUAL BEAM CAMBER. WHERE BOTTOM OF SLAB IS IN LINE WITH BOTTOM OF TOP FLANGES, DEPTH OF SLAB BETWEEN BEARINGS SHALL BE ADJUSTED TO COMPENSATE FOR DEAD LOAD DEFLECTION, VERTICAL CURVE ORDINATE, AND ACTUAL BEAM CAMBER.

IN SETTING FALSEWORK AND FORMS FOR REINFORCED CONCRETE SPANS, AN ALLOWANCE SHALL BE MADE FOR DEAD LOAD DEFLECTIONS, SETTLEMENT OF FALSEWORK, AND PERMANENT CAMBER WHICH SHALL BE PROVIDED FOR IN ADDITION TO THE ELEVATIONS SHOWN. AFTER REMOVAL OF THE FALSEWORK, THE FINISHED STRUCTURES SHALL CONFORM TO THE PROFILE AND ELEVATIONS SHOWN ON THE PLANS AND CONSTRUCTION ELEVATIONS FURNISHED BY THE ENGINEER.

DETAILED DRAWINGS FOR FALSEWORK OR FORMS FOR BRIDGE SUPERSTRUCTURE AND ANY STRUCTURE OR PARTS OF A STRUCTURE AS NOTED ON THE PLANS SHALL BE SUBMITTED TO THE ENGINEER FOR APPROVAL BEFORE CONSTRUCTION OF THE FALSEWORK OR FORMS IS STARTED.

REINFORCING STEEL:

ALL REINFORCING STEEL SHALL BE DEFORMED. DIMENSIONS RELATIVE TO PLACEMENT OF REINFORCING ARE TO CENTERS OF BARS UNLESS OTHERWISE INDICATED IN THE PLANS. DIMENSIONS ON BAR DETAILS ARE TO CENTERS OF BARS OR ARE OUT TO OUT AS INDICATED ON PLANS.

WIRE BAR SUPPORTS SHALL BE PROVIDED FOR REINFORCING STEEL WHERE INDICATED ON THE PLANS. WHEN BAR SUPPORT PIECES ARE PLACED IN CONTINUOUS LINES, THEY SHALL BE SO PLACED THAT THE ENDS OF THE SUPPORTING WIRES SHALL BE LAPPED TO LOCK LEGS ON ADJOINING PIECES.

STRUCTURAL STEEL:

AT THE CONTRACTOR'S OPTION, HE MAY SUBSTITUTE 7/8" Ø SHEAR STUDS FOR THE 3/4" Ø STUDS SPECIFIED ON THE PLANS. THIS SUBSTITUTION SHALL BE MADE AT THE RATE OF 3 - 7/8" Ø STUDS FOR 4 - 3/4" Ø STUDS, AND STUD SPACING CHANGES SHALL BE MADE AS NECESSARY TO PROVIDE THE SAME EQUIVALENT NUMBER OF 7/8" Ø STUDS ALONG THE BEAM AS SHOWN FOR 3/4" Ø STUDS BASED ON THE RATIO OF 3 - 7/8" Ø STUDS FOR 4 - 3/4" Ø STUDS. STUDS OF THE LENGTH SPECIFIED ON THE PLANS MUST BE PROVIDED. THE MAXIMUM SPACING SHALL BE 2'-0".

EXCEPT AT THE INTERIOR SUPPORTS OF CONTINUOUS BEAMS WHERE THE COVER PLATE IS IN CONTACT WITH BEARING PLATE, THE CONTRACTOR MAY, AT HIS OPTION, SUBSTITUTE FOR THE COVER PLATES DESIGNATED ON THE PLANS COVER PLATES OF THE EQUIVALENT AREA PROVIDED THESE PLATES ARE AT LEAST 5/16" IN THICKNESS AND DO NOT EXCEED A WIDTH EQUAL TO THE FLANGE WIDTH LESS 2" OR A THICKNESS EQUAL TO 2 TIMES THE FLANGE THICKNESS. THE SIZE OF FILLET WELDS SHALL CONFORM TO THE REQUIREMENTS OF THE CURRENT ANSI/AASHTO/AWS "BRIDGE WELDING CODE". ELECTROSLAG WELDING WILL NOT BE PERMITTED.

WITH THE SOLE EXCEPTION OF EDGES AT SURFACES WHICH BEAR ON OTHER SURFACES, ALL SHARP EDGES AND ENDS OF SHAPES AND PLATES SHALL BE SLIGHTLY ROUNDED BY SUITABLE MEANS TO A RADIUS OF APPROXIMATELY 1/16 INCH OR EQUIVALENT FLAT SURFACE AT A SUITABLE ANGLE PRIOR TO PAINTING, GALVANIZING, OR METALLIZING.

HANDRAILS AND POSTS:

METAL STANDARDS AND FACES OF THE CONCRETE END POSTS FOR THE METAL RAIL SHALL BE SET NORMAL TO THE GRADE OF THE CURB, UNLESS OTHERWISE SHOWN ON PLANS. THE METAL RAIL AND TOPS OF CONCRETE POSTS USED WITH THE ALUMINUM RAIL SHALL BE BUILT PARALLEL TO THE GRADE OF THE CURB.

METAL HANDRAILS SHALL BE IN ACCORDANCE WITH THE PLANS. RAILS SHALL BE AS MANUFACTURED FOR BRIDGE RAILING. CASTINGS SHALL BE OF A UNIFORM APPEARANCE. FINS AND OTHER DEFORMATIONS RESULTING FROM CASTING OR OTHERWISE SHALL BE REMOVED IN A MANNER SO THAT A UNIFORM COLORING OF THE COMPLETED CASTING SHALL BE OBTAINED. CASTINGS WITH DISCOLORATIONS OR OF NON-UNIFORM COLORING WILL NOT BE ACCEPTED. CERTIFIED MILL REPORTS ARE REQUIRED FOR METAL RAILS AND POSTS.

SPECIAL NOTES:

GENERALLY, IN CASE OF DISCREPANCY, THIS STANDARD SHEET OF NOTES SHALL GOVERN OVER THE SPECIFICATIONS, BUT THE REMAINDER OF THE PLANS SHALL GOVERN OVER NOTES HEREON, AND SPECIAL PROVISIONS SHALL GOVERN OVER ALL. SEE SPECIFICATIONS ARTICLE 105-4.

ENGLISH

JANUARY, 1990

STD. NO. SN